

TERMINAL 2 – FIXED LINKS AND NODES

PIER E, FIXED LINKS & NODE BUILDINGS – TERMINAL 2 – DUBLIN AIRPORT

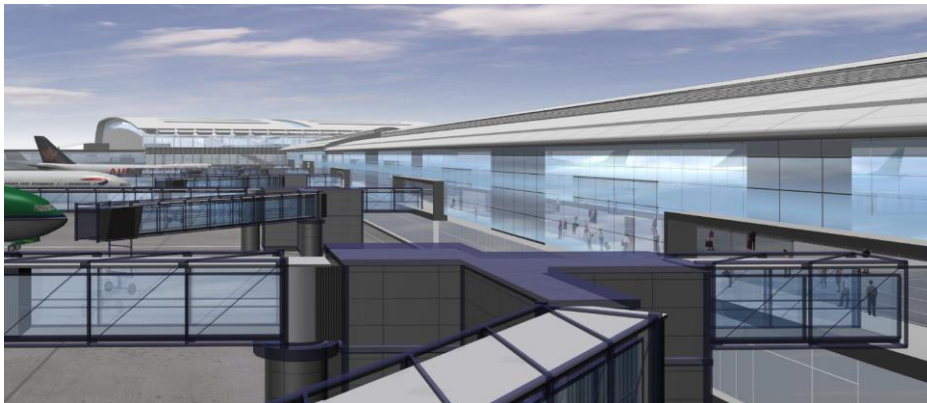

PASCALL+WATSON ARCHITECTS 3D PLANNING IMAGES OF PIER E



PASCALL+WATSON ARCHITECTS 3D IMAGE, FIXED LINKS & NODE BUILDINGS



PASCALL+WATSON ARCHITECTS INTERNAL 3D IMAGE

KEY PLAN

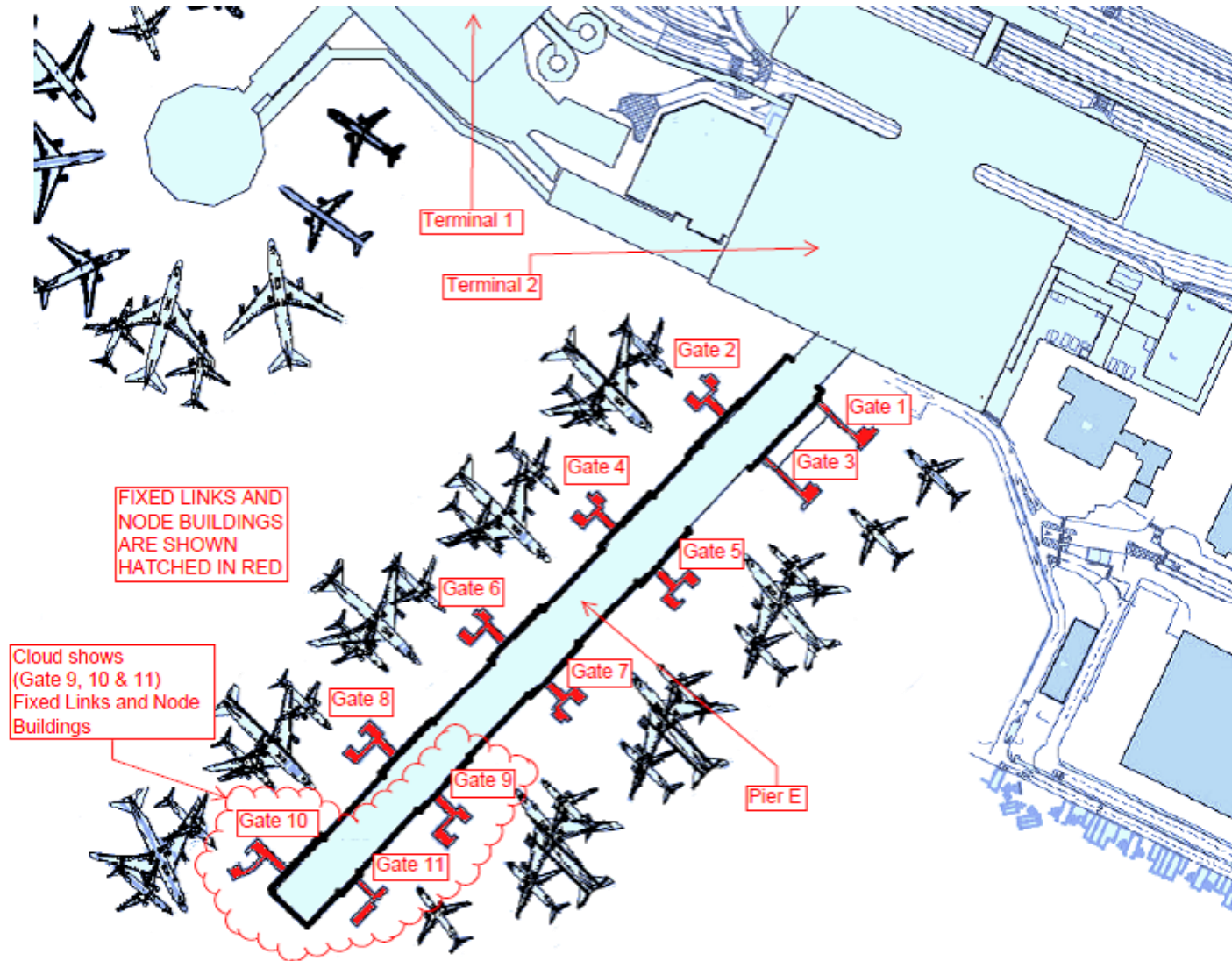

GROUND FLOOR PLANS FIXED LINKS GATE 9-11

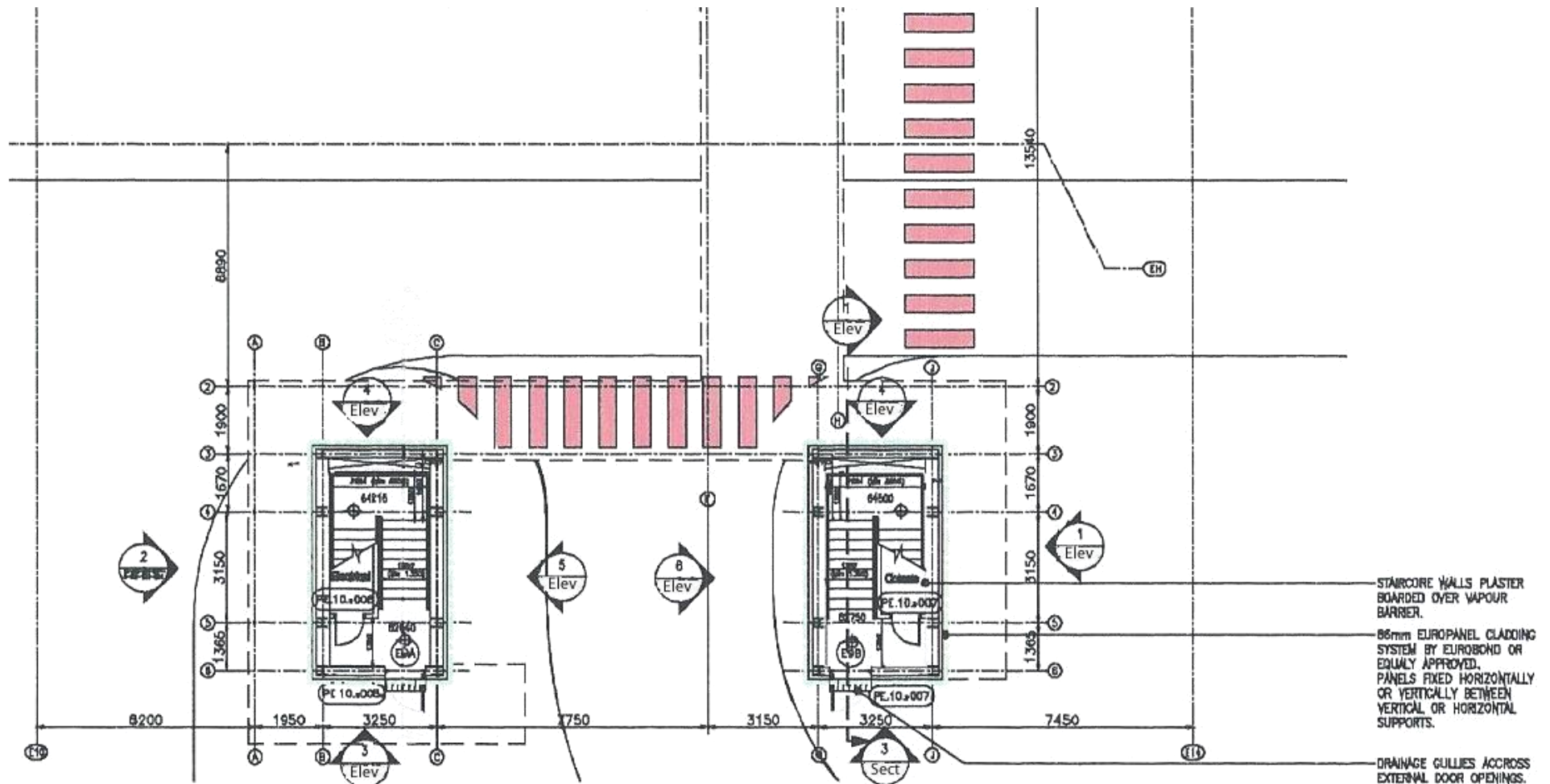

FIXED LINK TUNNEL & NODE BUILDING - GATE 9

GROUND FLOOR PLANS FIXED LINKS GATE 9-11

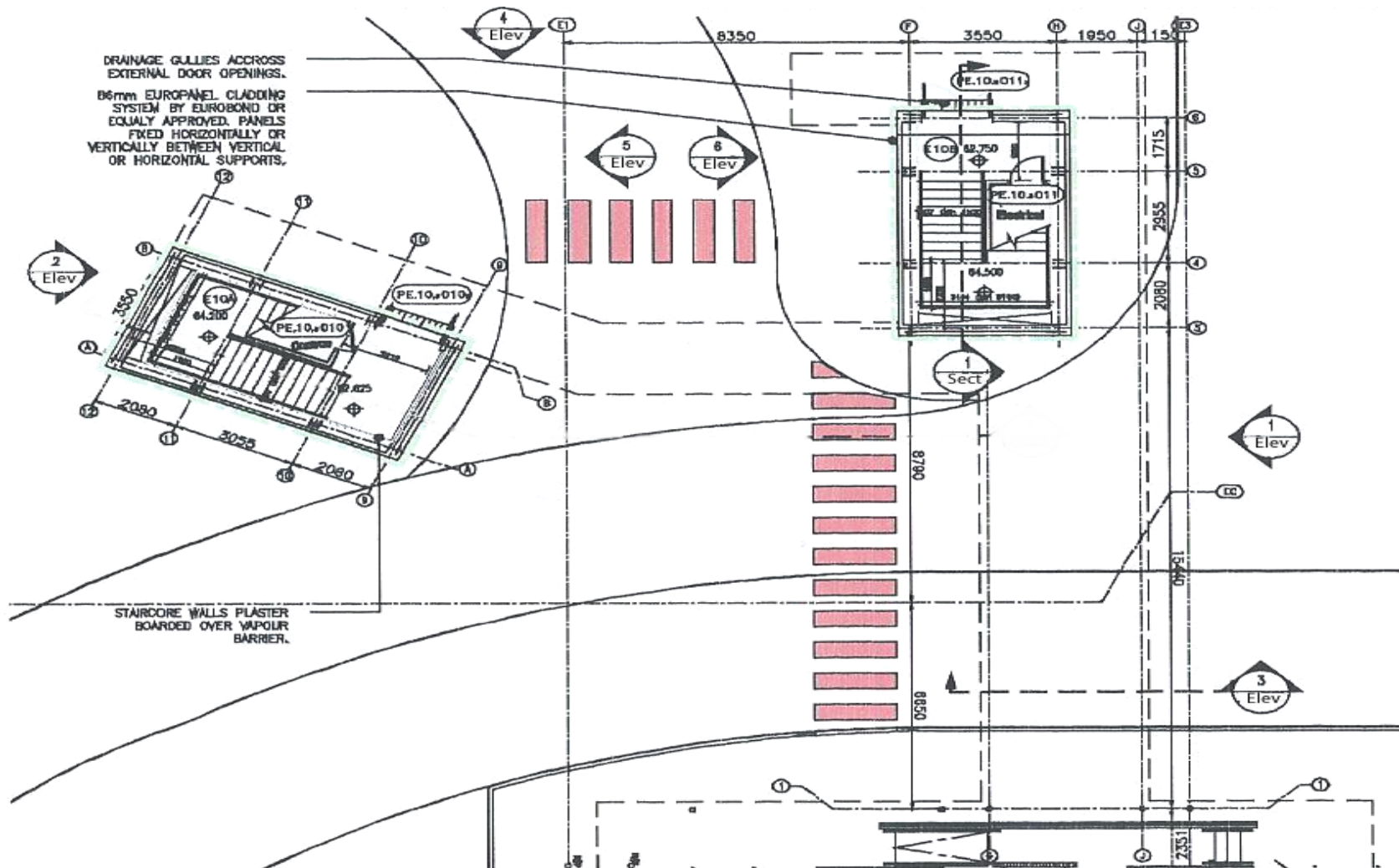

FIXED LINK TUNNEL & NODE BUILDING - GATE 10

GROUND FLOOR PLANS FIXED LINKS GATE 9-11

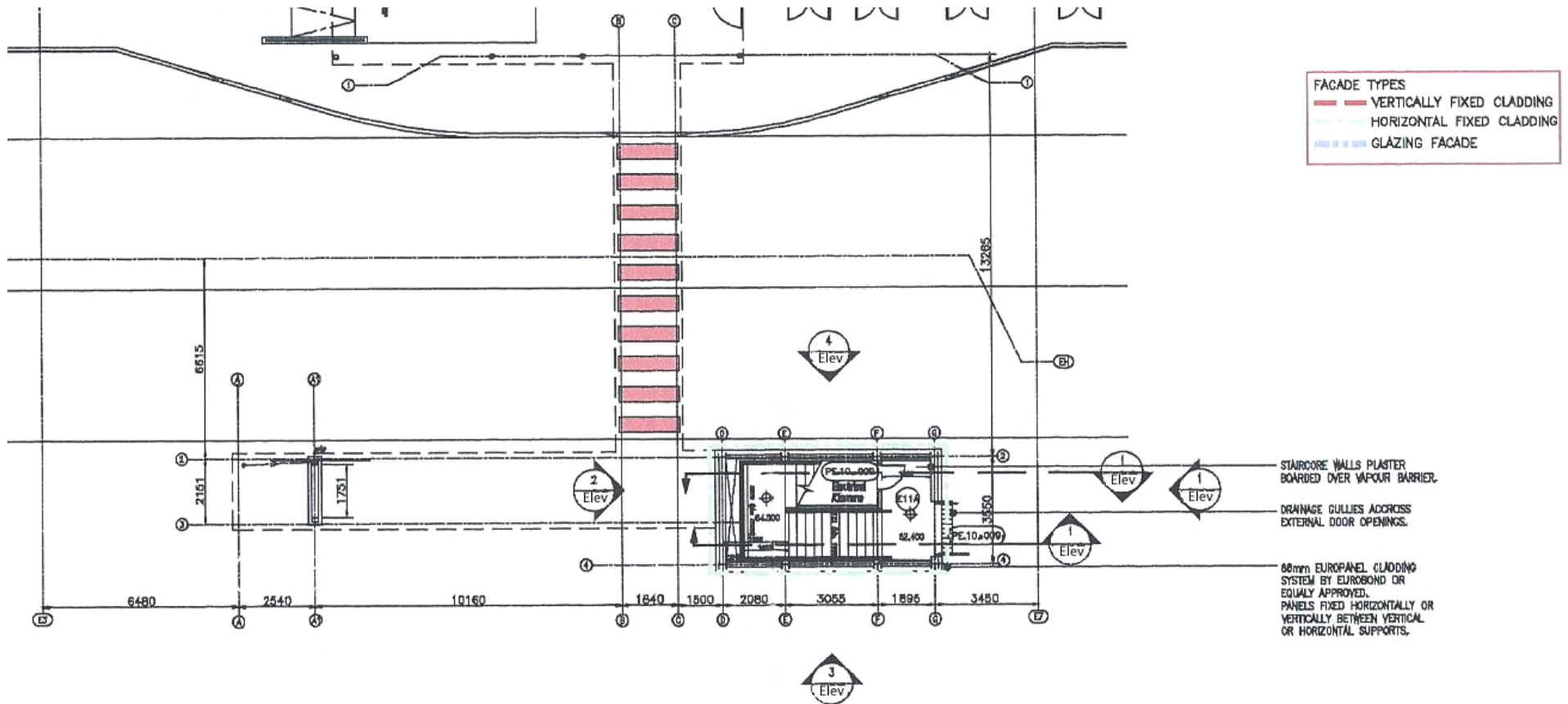

FIXED LINK TUNNEL & NODE BUILDING - GATE 11

FIRST FLOOR PLANS FIXED LINKS GATE 9-11

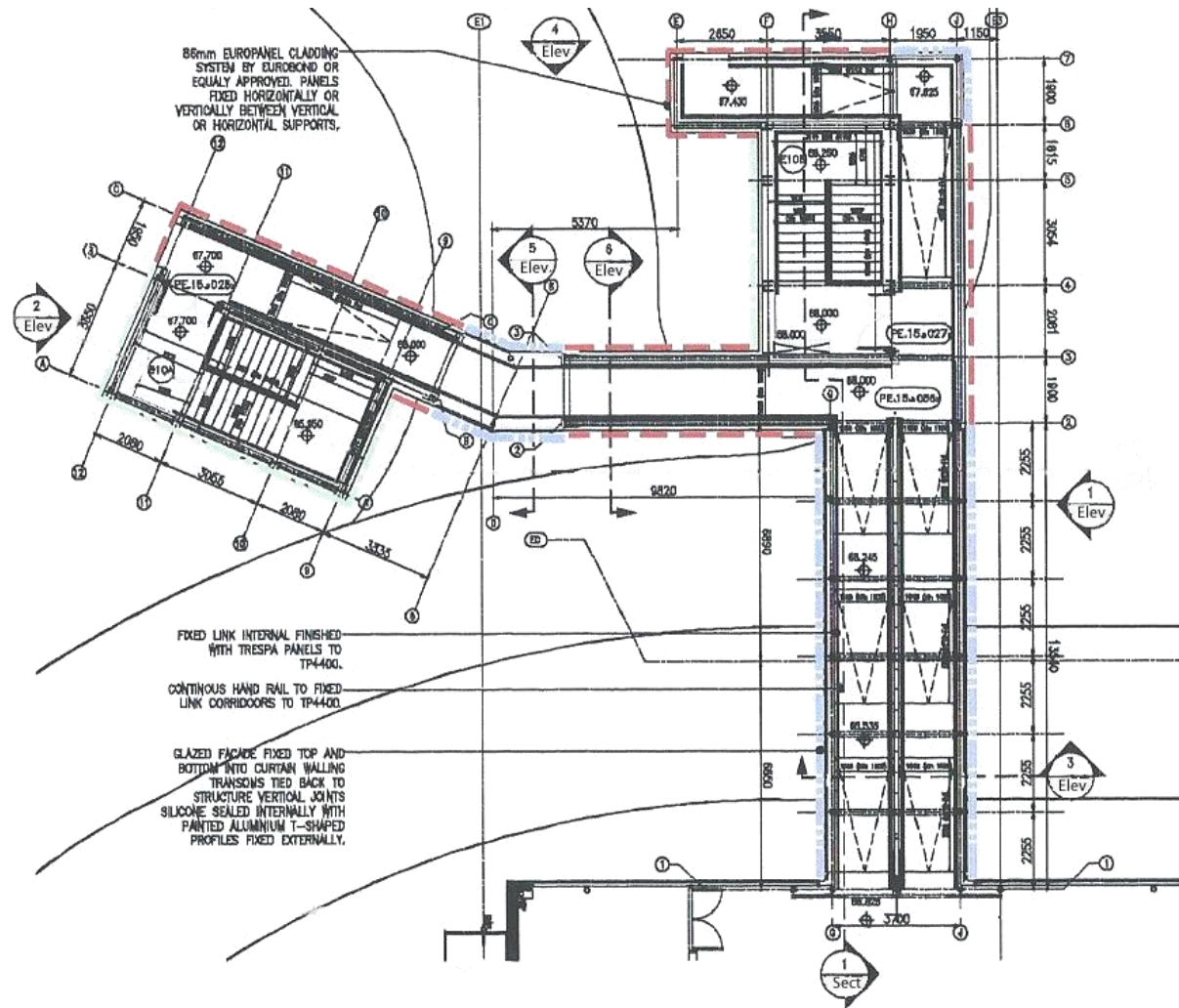

FIXED LINK TUNNEL & NODE BUILDING - GATE 10

ROOF PLANS FIXED LINKS GATE 9-11

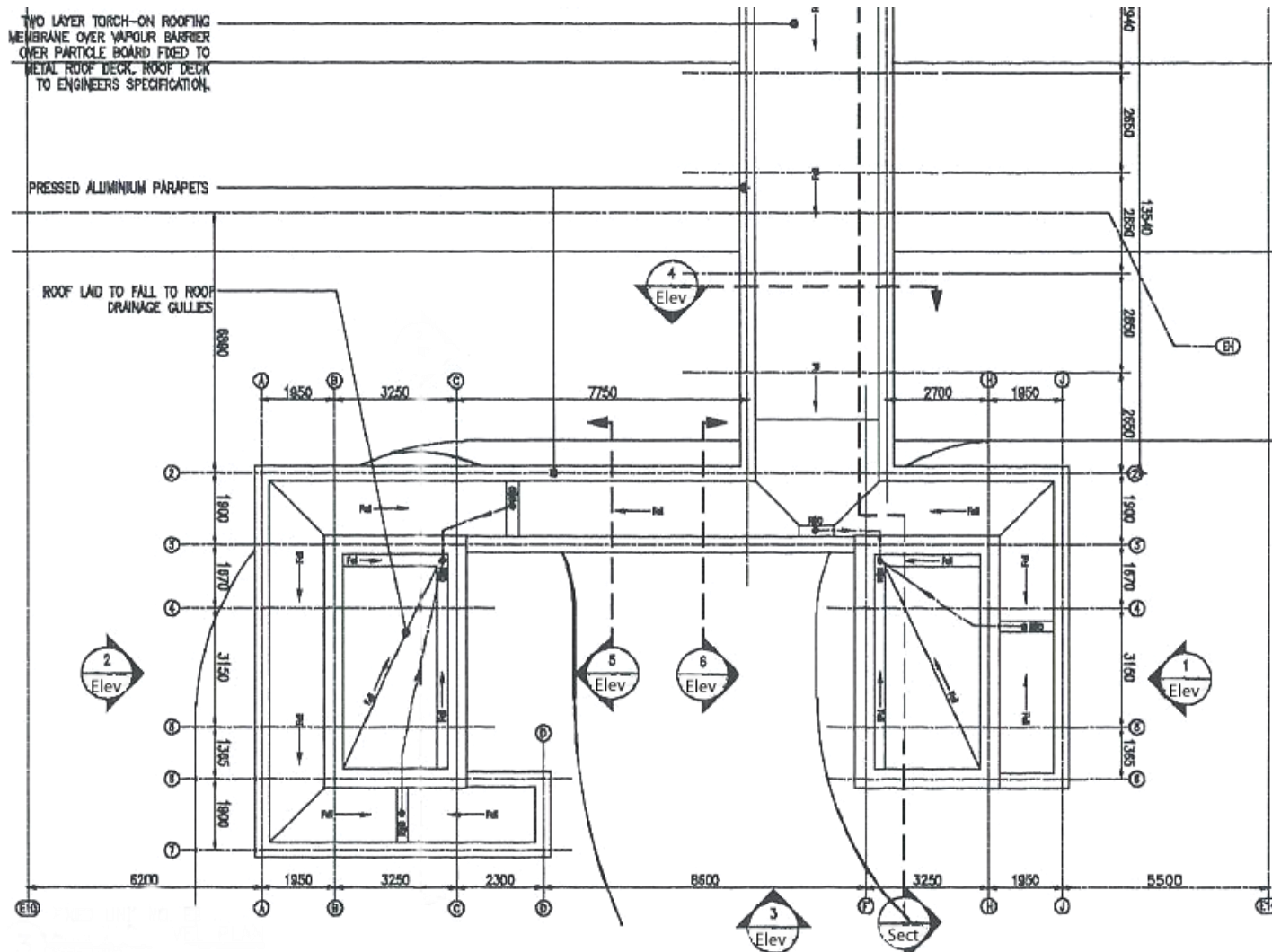

FIXED LINK TUNNEL & NODE BUILDING - GATE 9

ROOF PLANS FIXED LINKS GATE 9-11

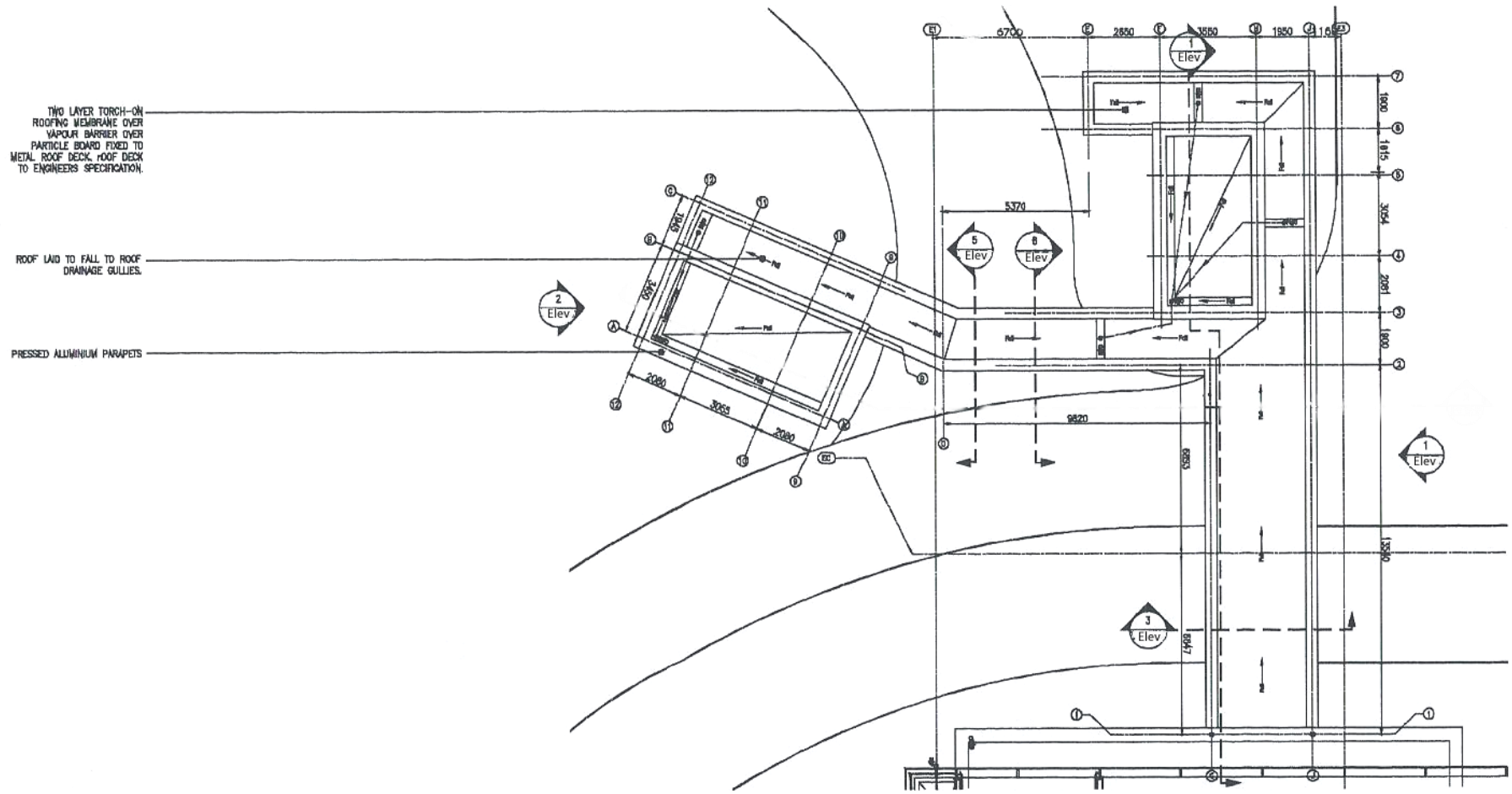

FIXED LINK TUNNEL & NODE BUILDING - GATE 10

ROOF PLANS FIXED LINKS GATE 9-11

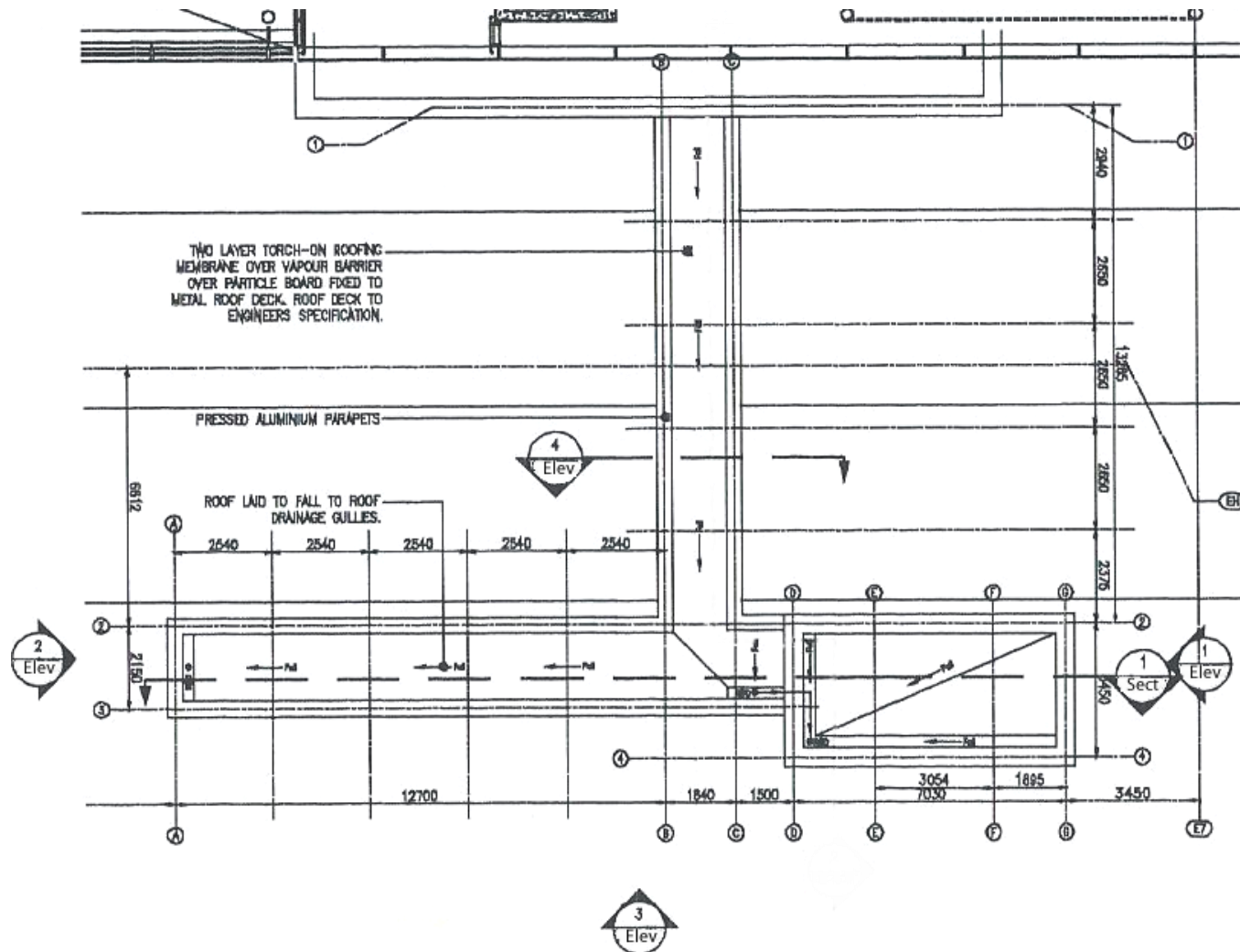

FIXED LINK TUNNEL & NODE BUILDING - GATE 11

GATE 9 ELEVATIONS

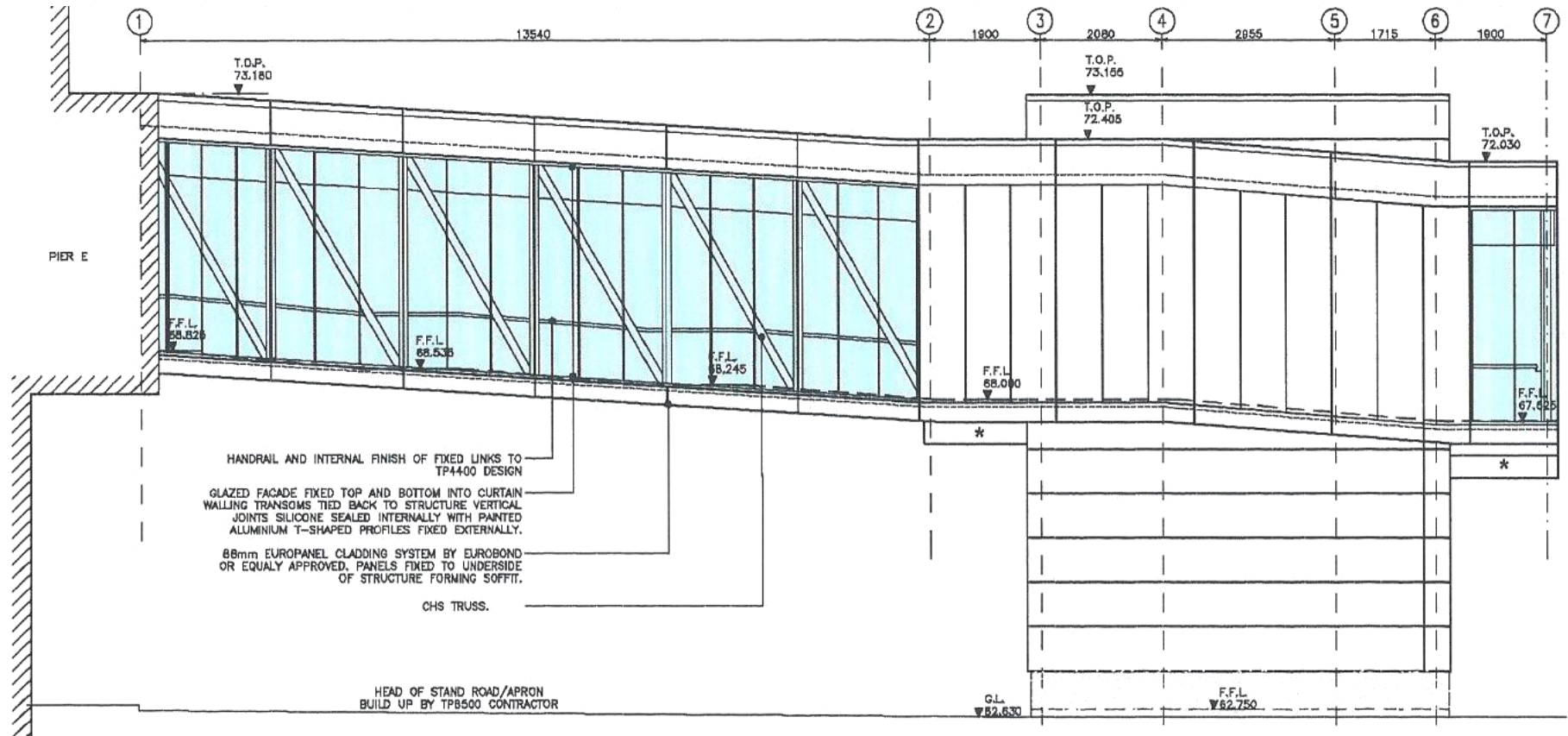

GATE 9 - ELEVATION 1

GATE 9 ELEVATIONS

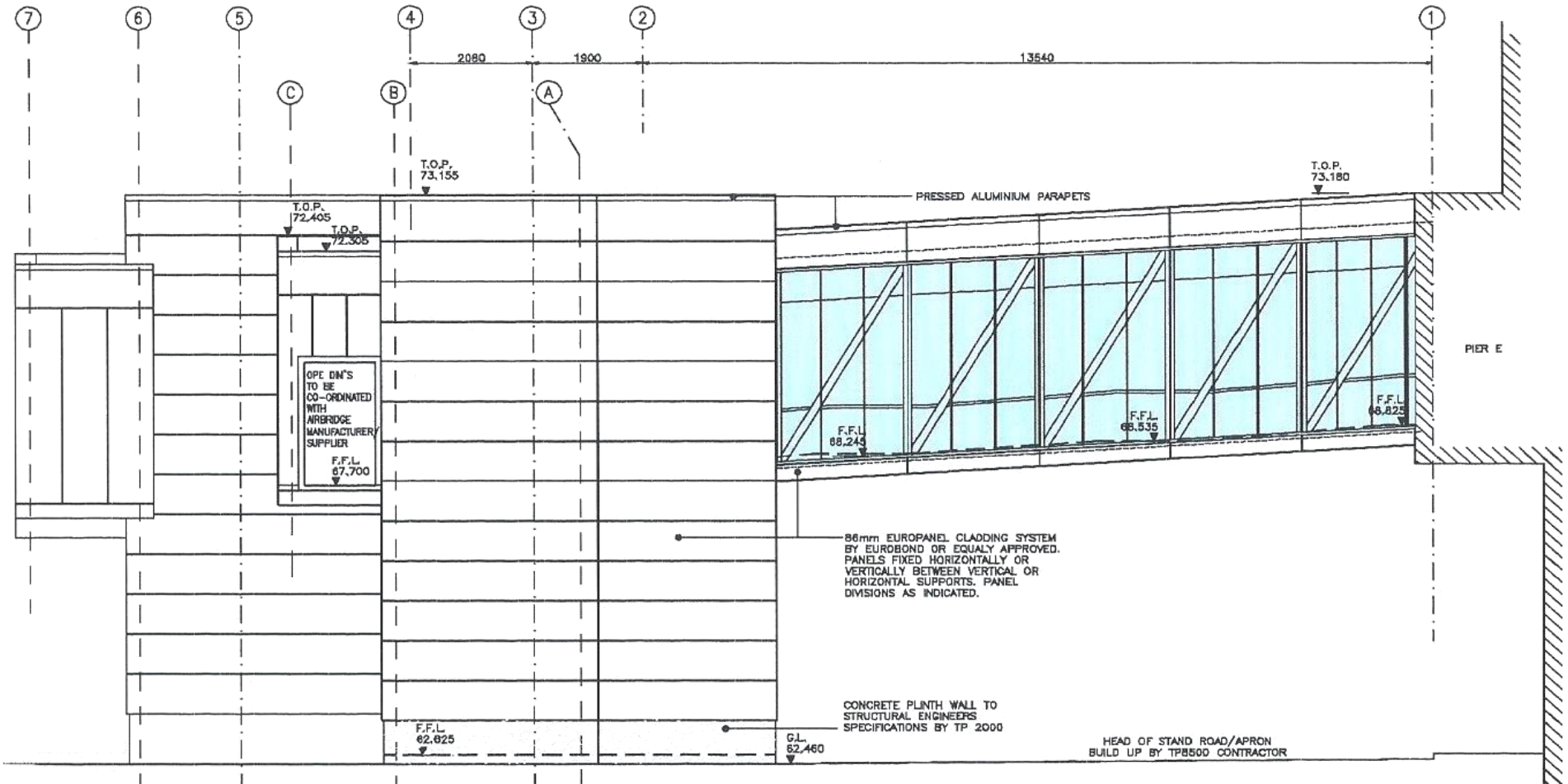

GATE 9 - ELEVATION 2

GATE 9 ELEVATIONS

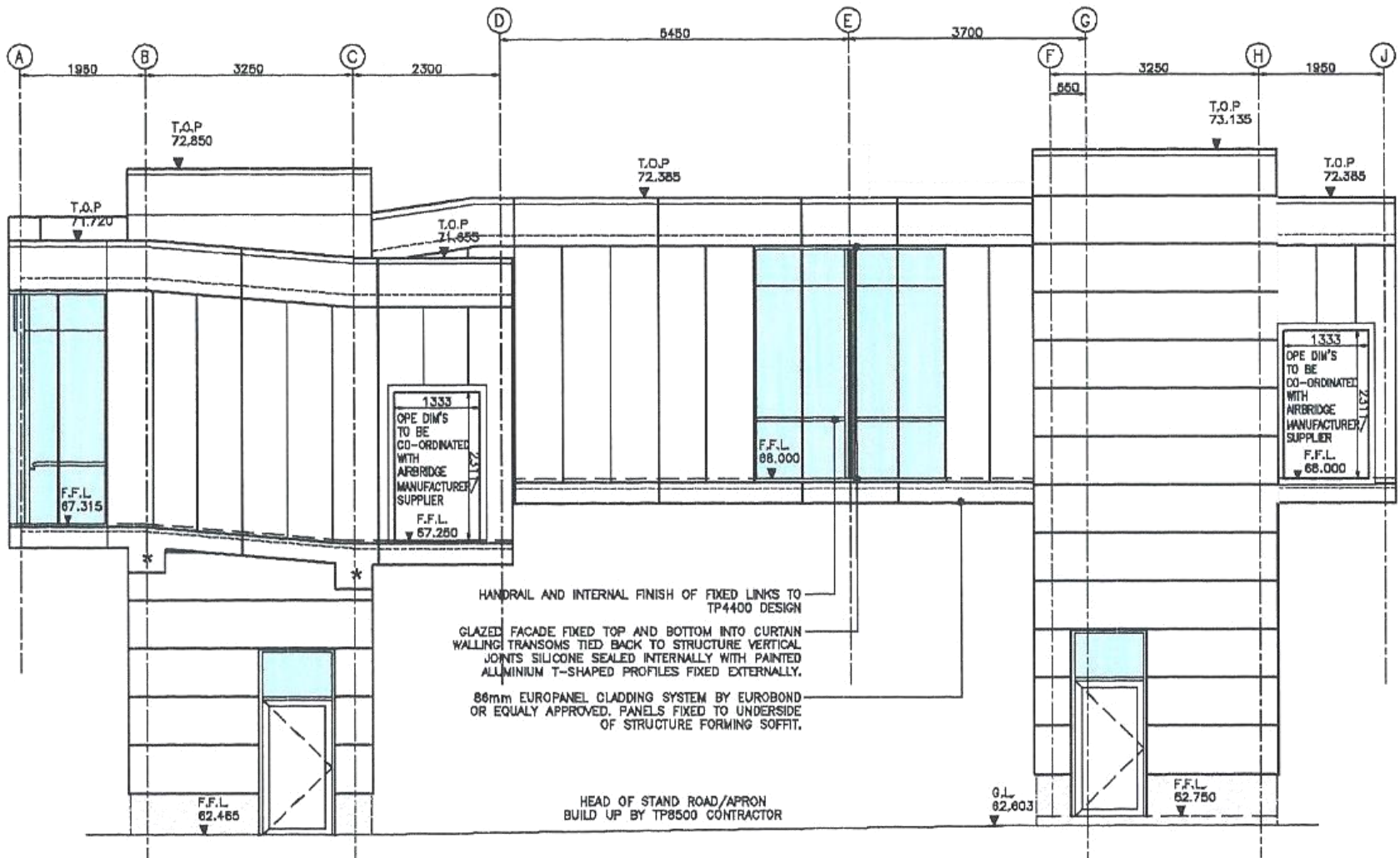

GATE 9 - ELEVATION 3

GATE 9 ELEVATIONS

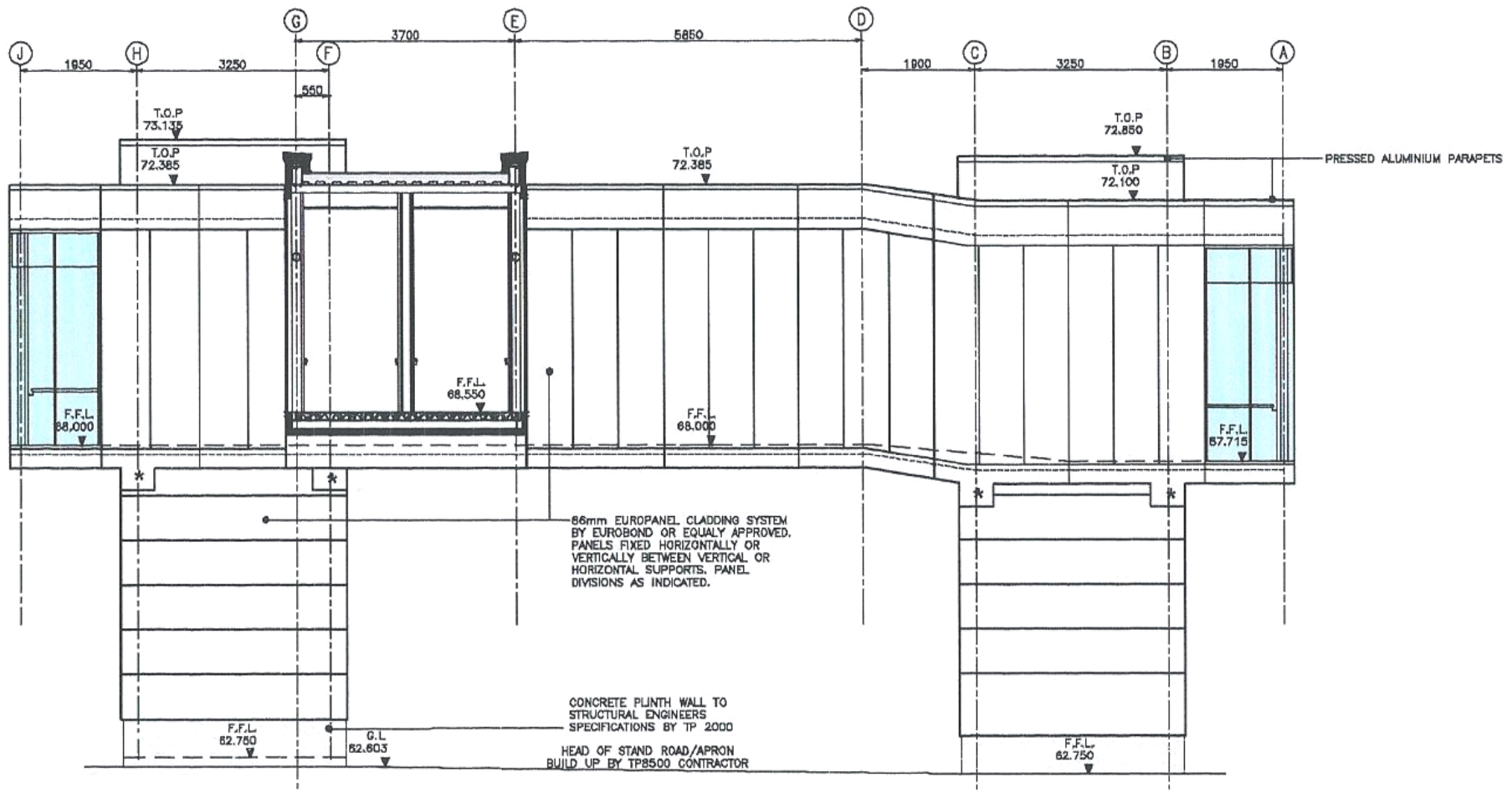

GATE 9 - ELEVATION 4

GATE 9 ELEVATIONS

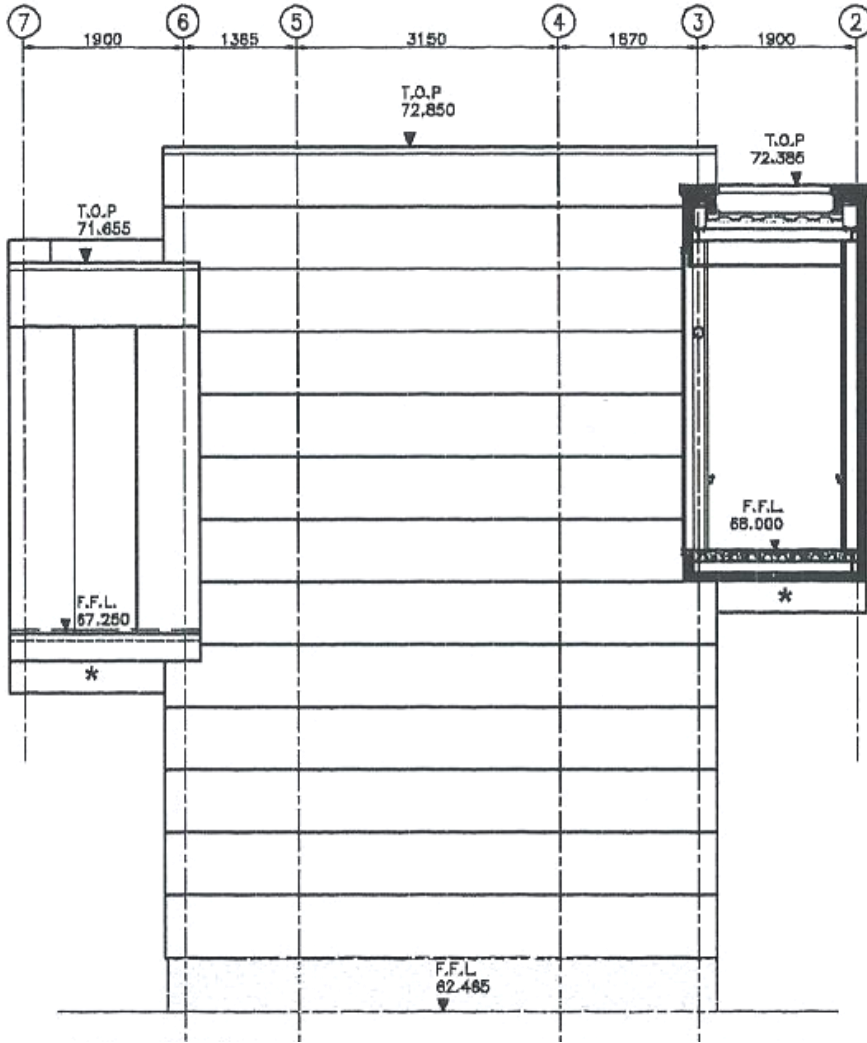

GATE 9 - ELEVATION 5

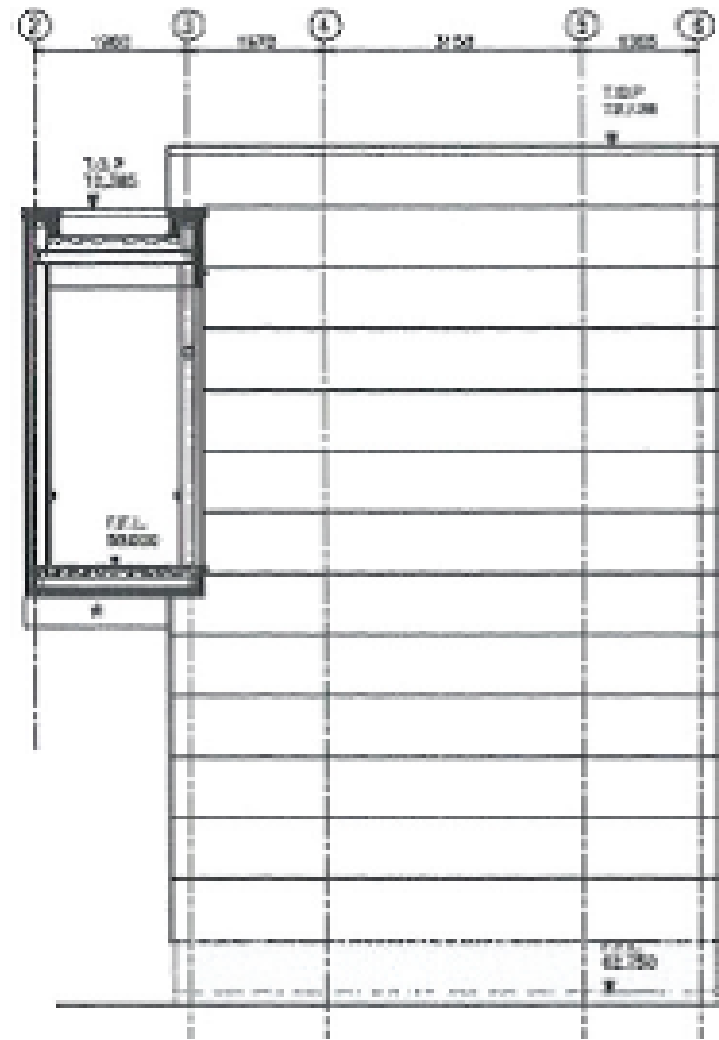

GATE 9 - ELEVATION 6

GATE 10 ELEVATIONS

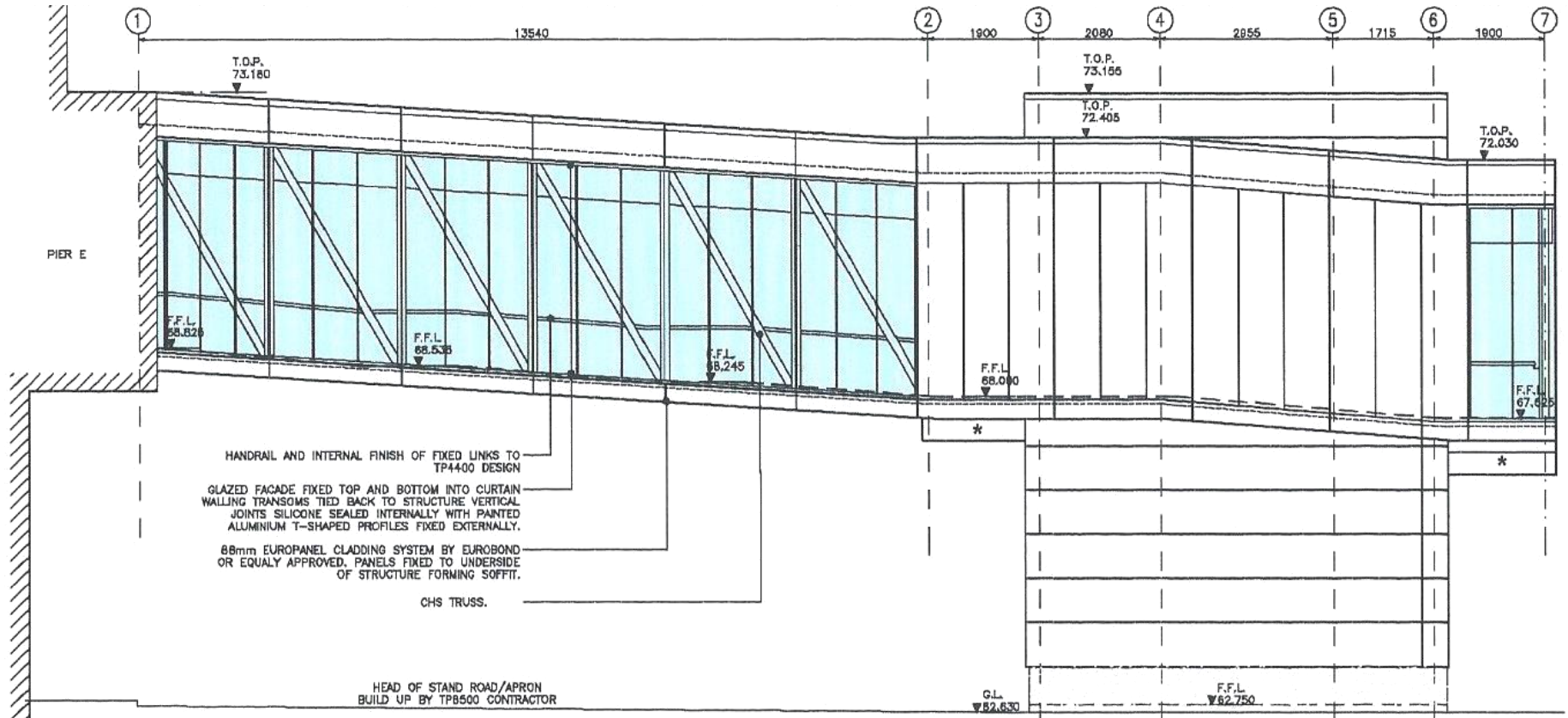

GATE 10 - ELEVATION 1

GATE 10 ELEVATIONS

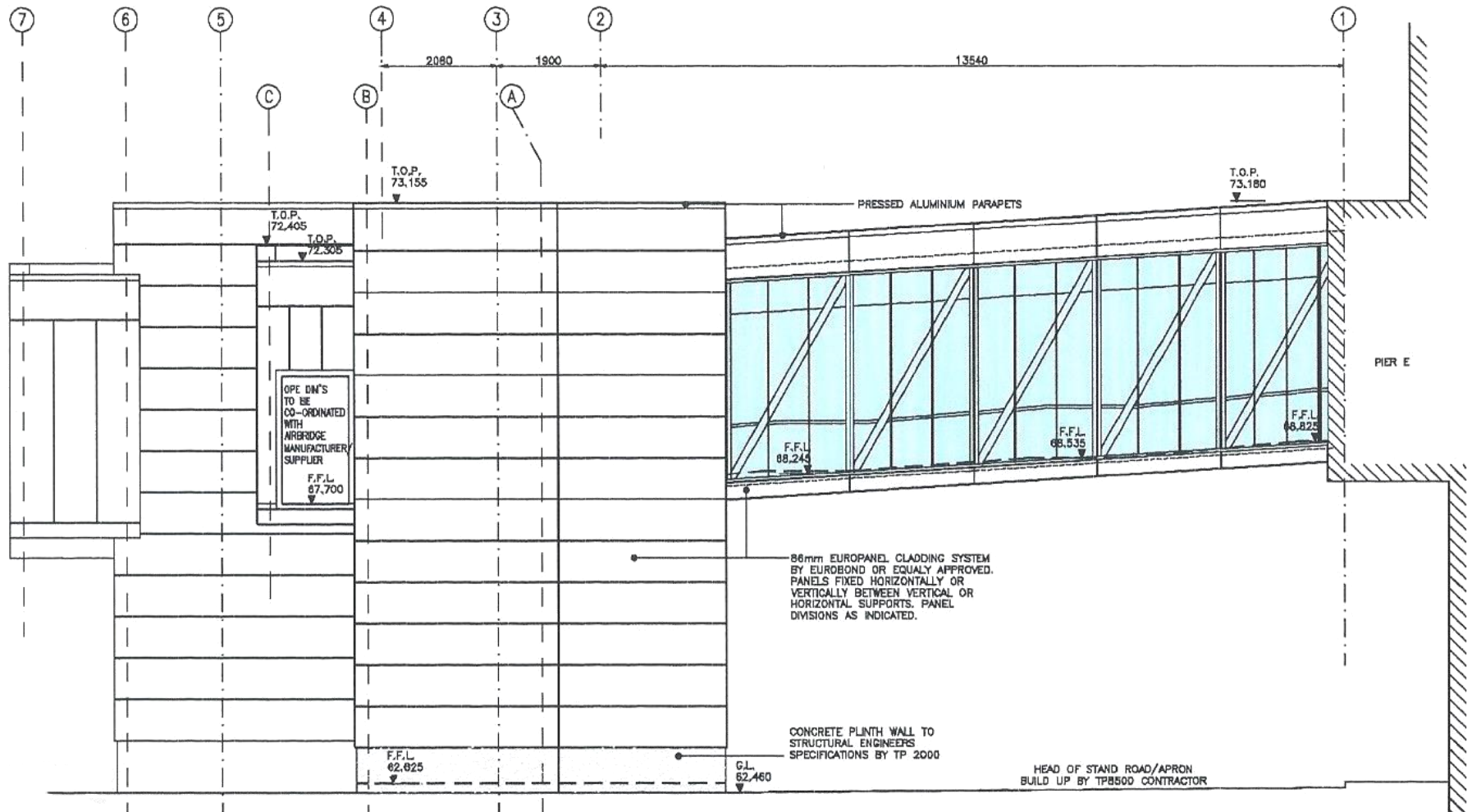

GATE 10 - ELEVATION 2

GATE 10 ELEVATIONS

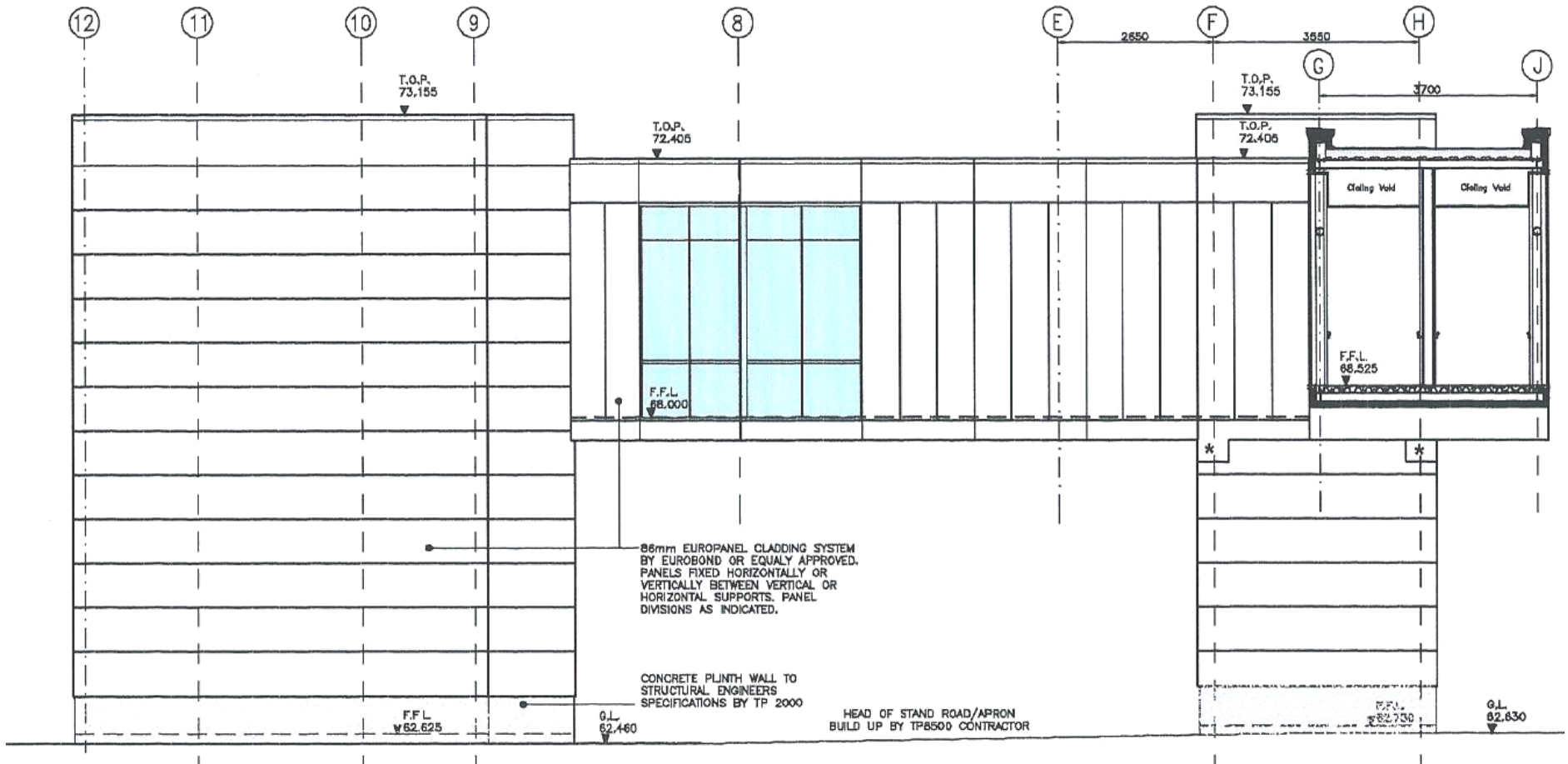

GATE 10 - ELEVATION 3

GATE 10 ELEVATIONS

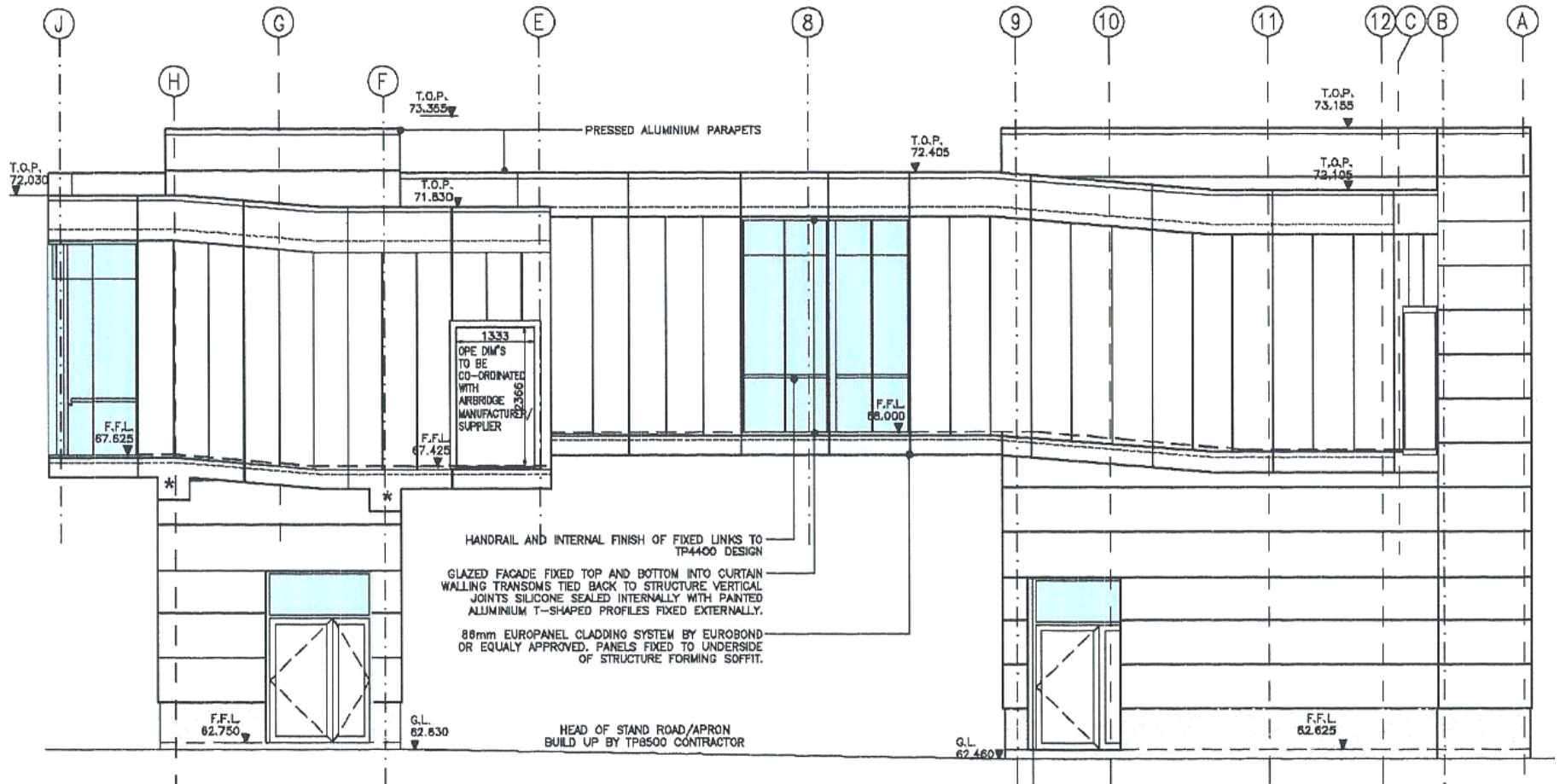

GATE 10 - ELEVATION 4

GATE 11 ELEVATIONS

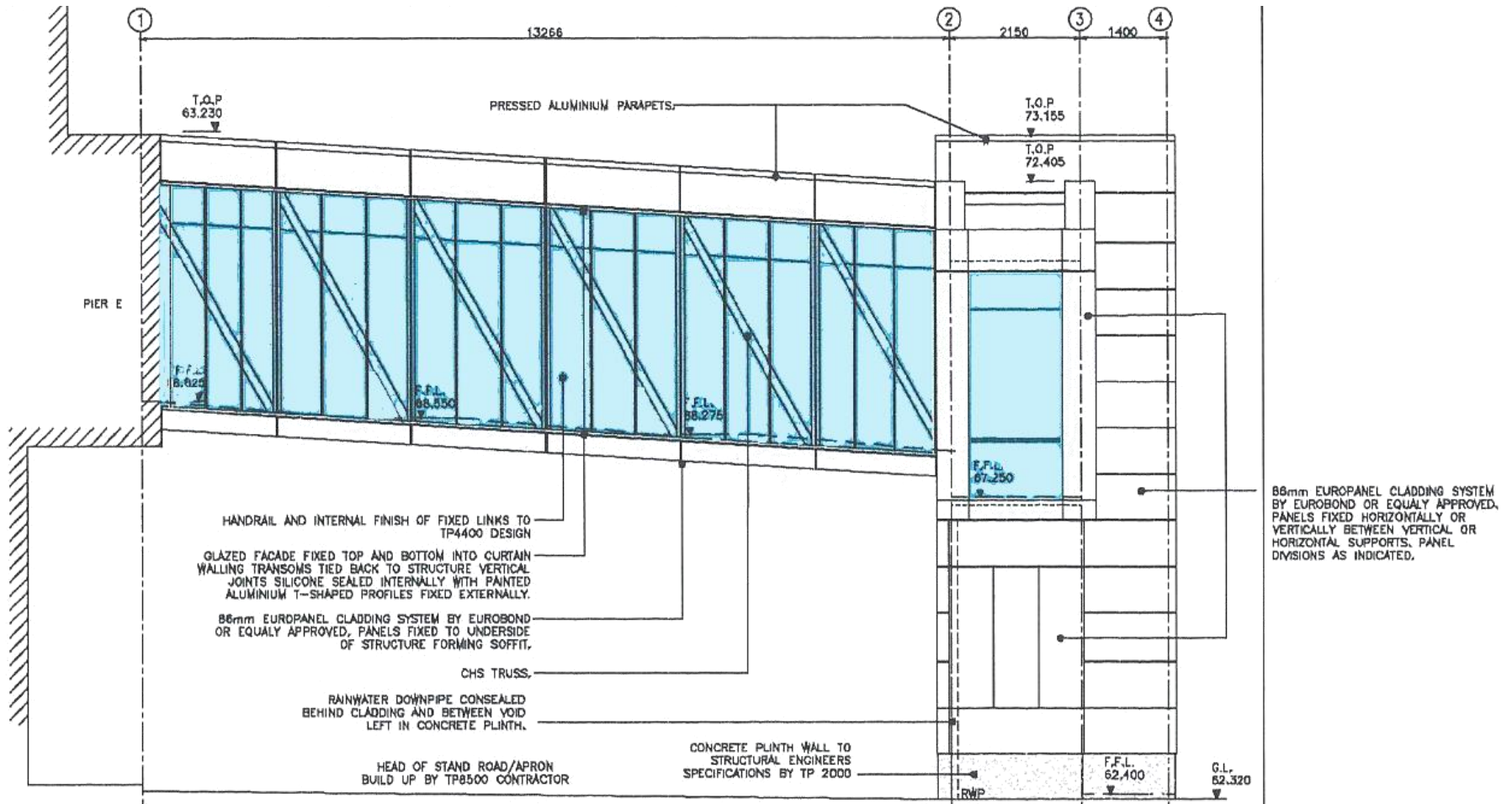

GATE 11 - ELEVATION 1

GATE 11 ELEVATIONS

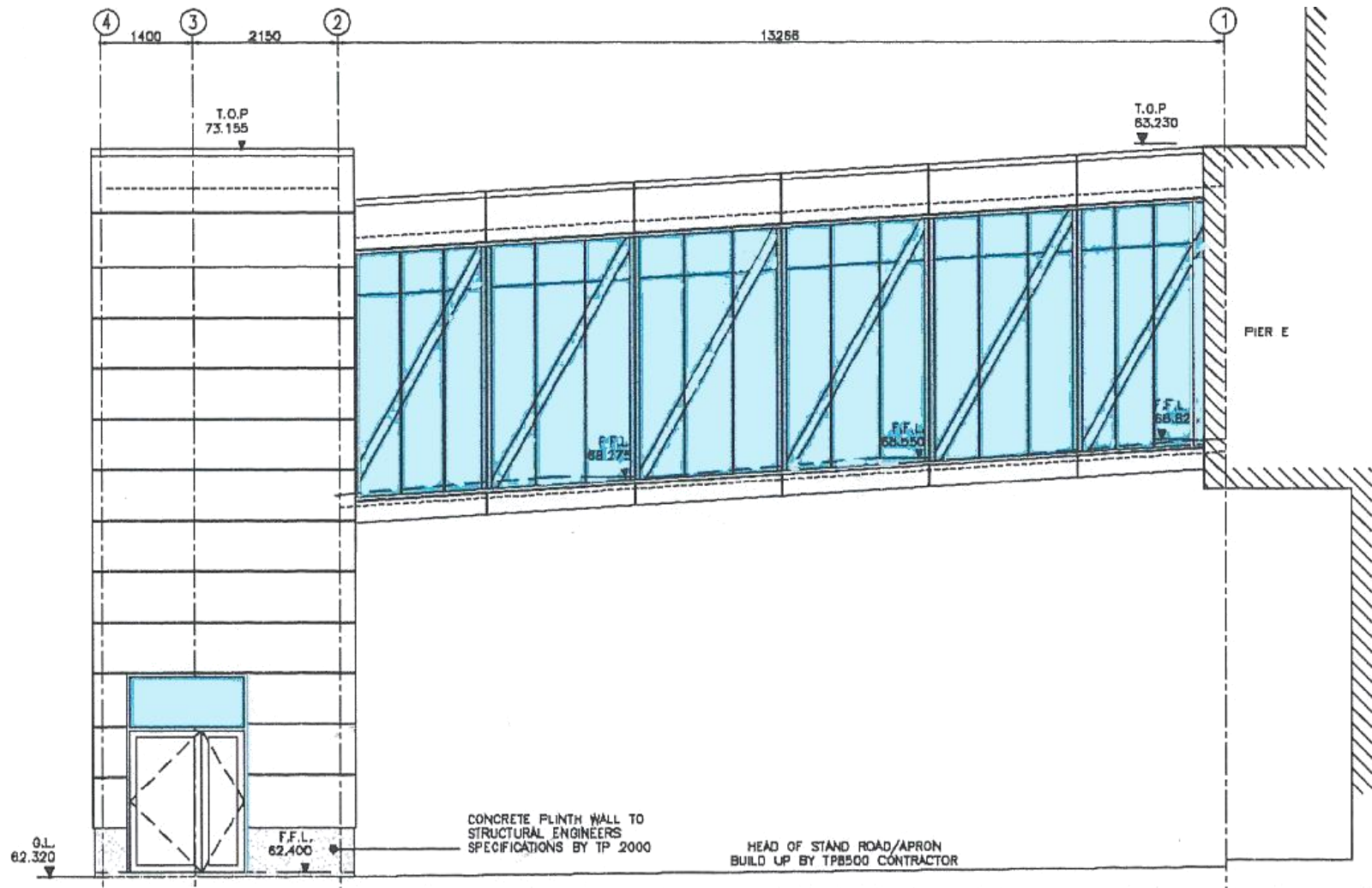

GATE 11 - ELEVATION 2

GATE 11 ELEVATIONS

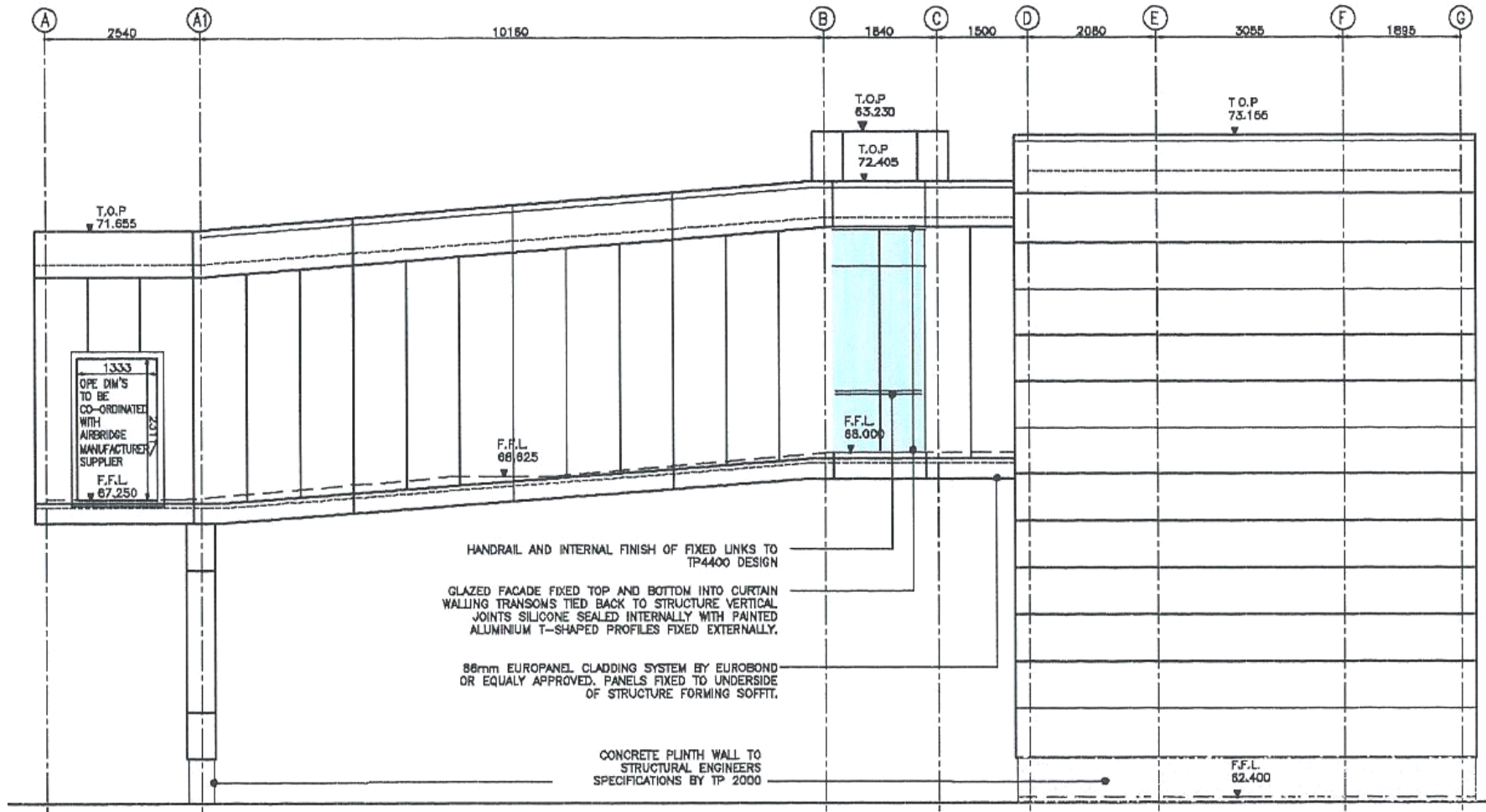

GATE 11 - ELEVATION 3

GATE 11 ELEVATIONS

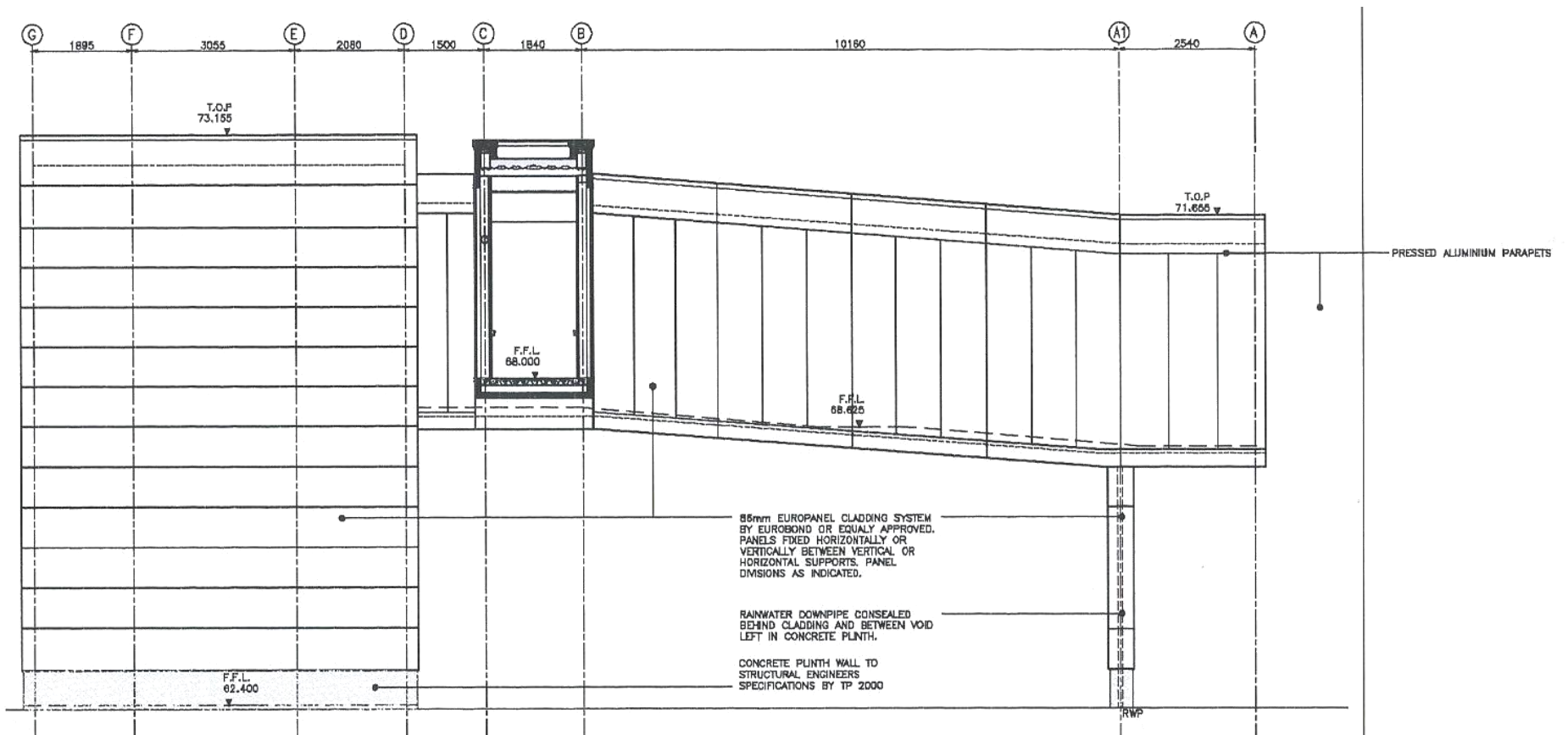

GATE 11 - ELEVATION 4

GATE 9 SECTION

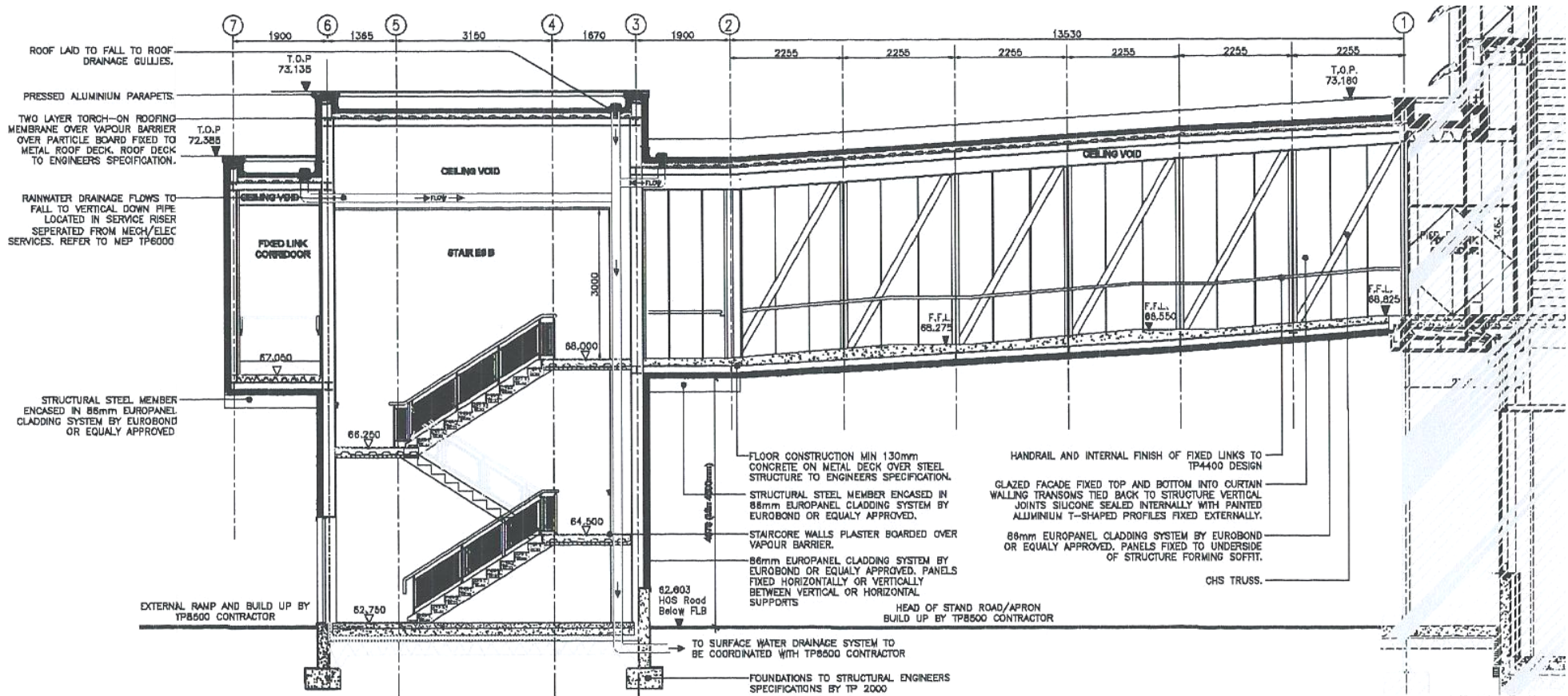

GATE 9 - SECTION

GATE 10 SECTION

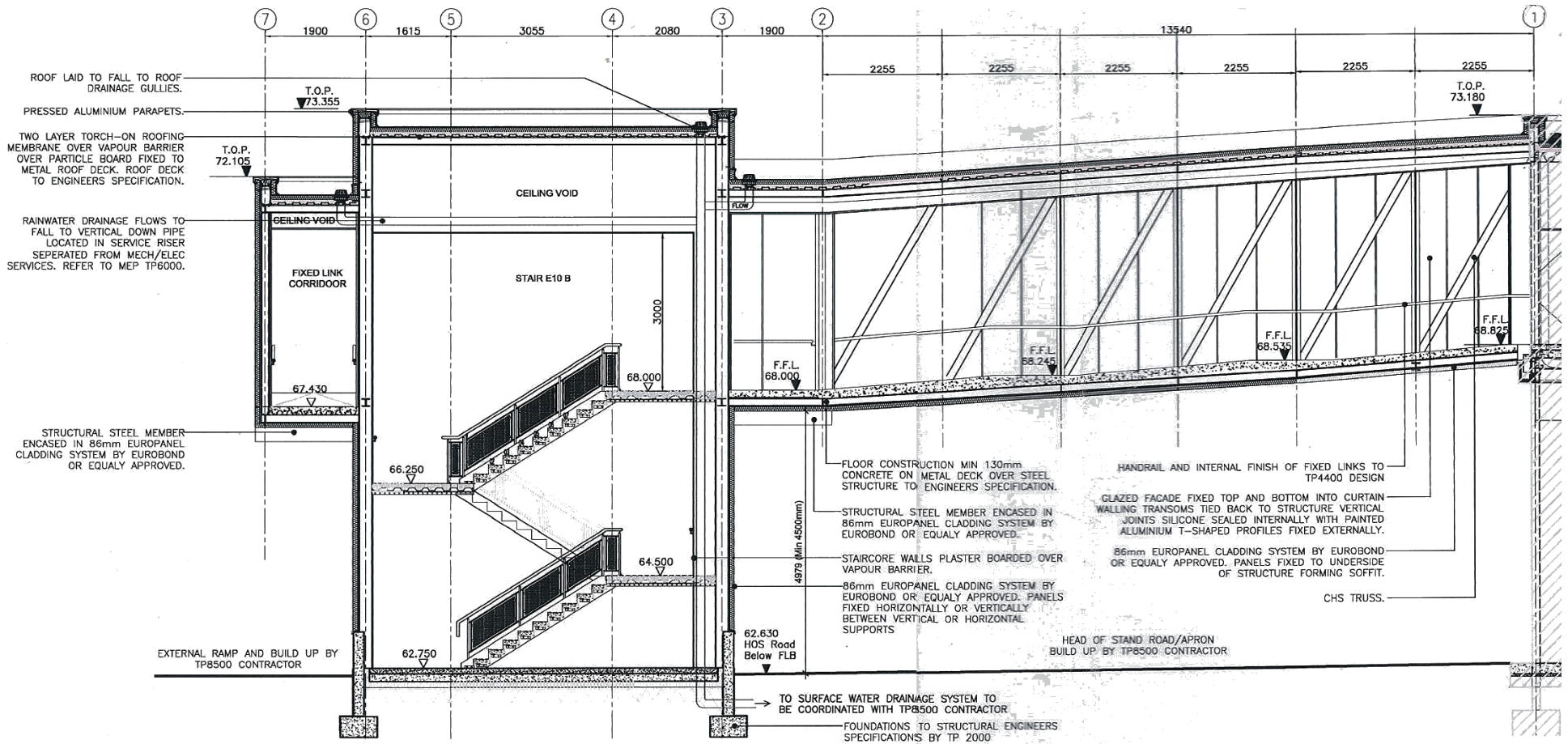

GATE 10 - SECTION

GATE 11 SECTIONS

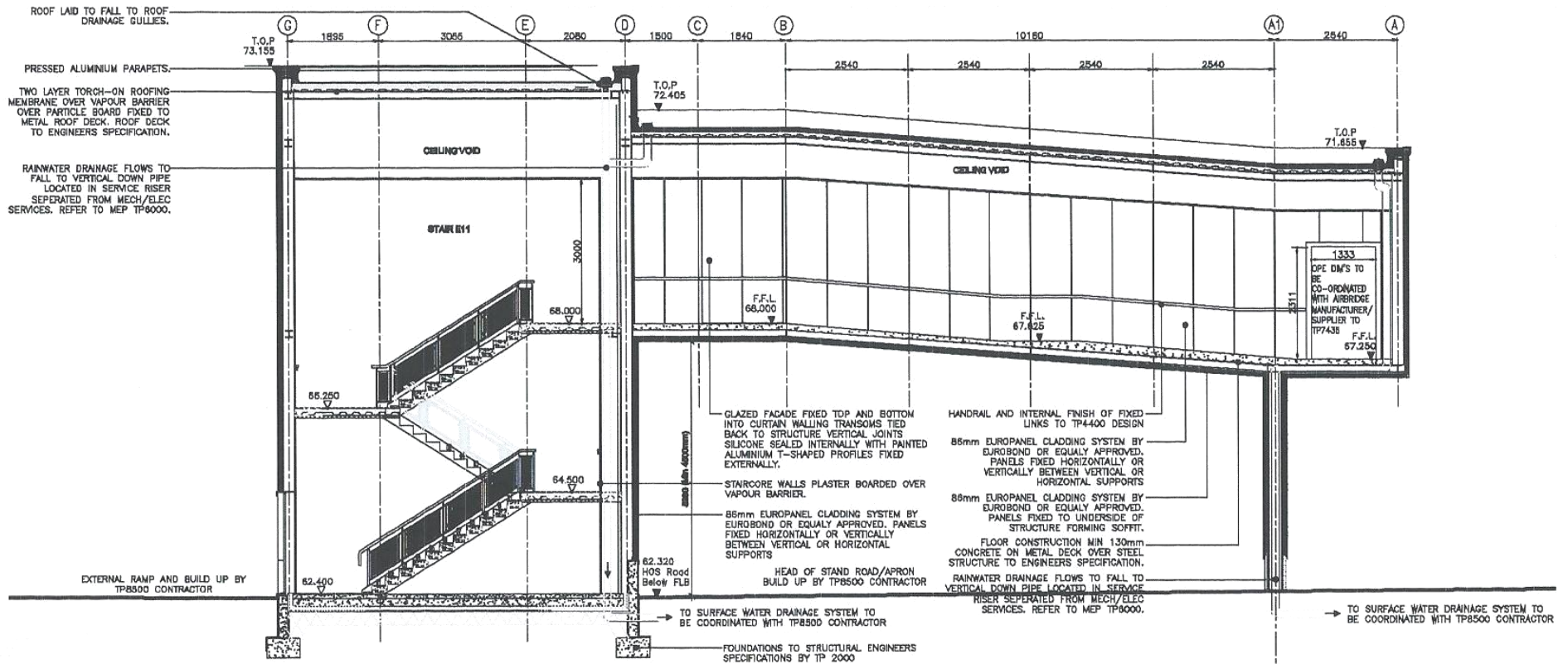

GATE 11 - SECTION

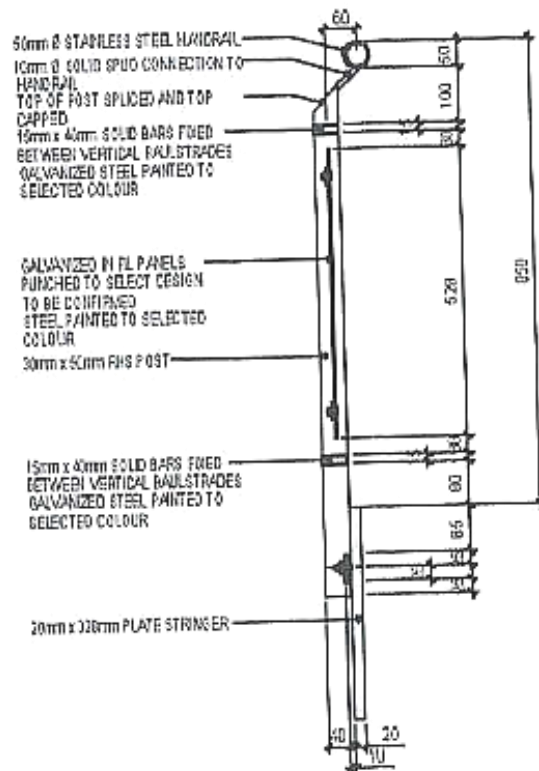

TYPICAL STAIR HANDRAIL SECTION THROUGH BALUSTRADE

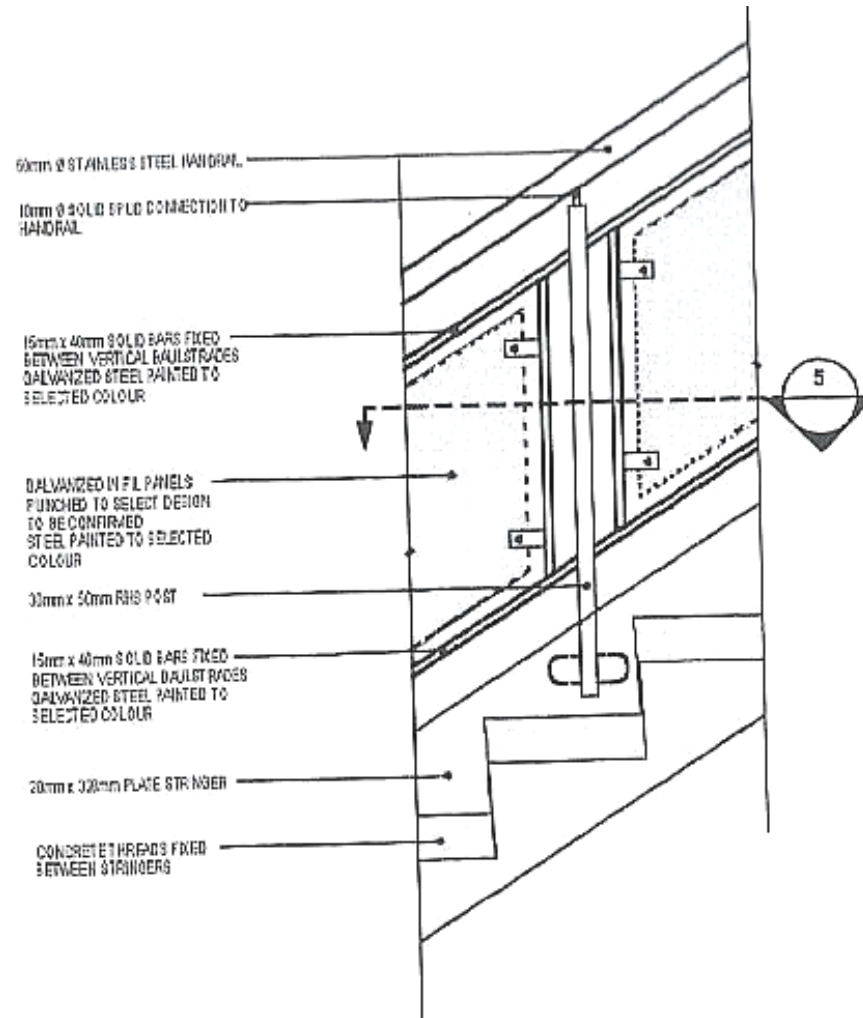

TYPICAL STAIR HANDRAIL SECTION SHOWING MID BALUSTRADE

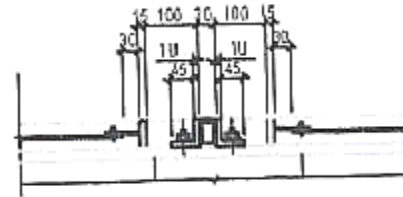

TYPICAL STAIR HANDRAIL DTAIL 5

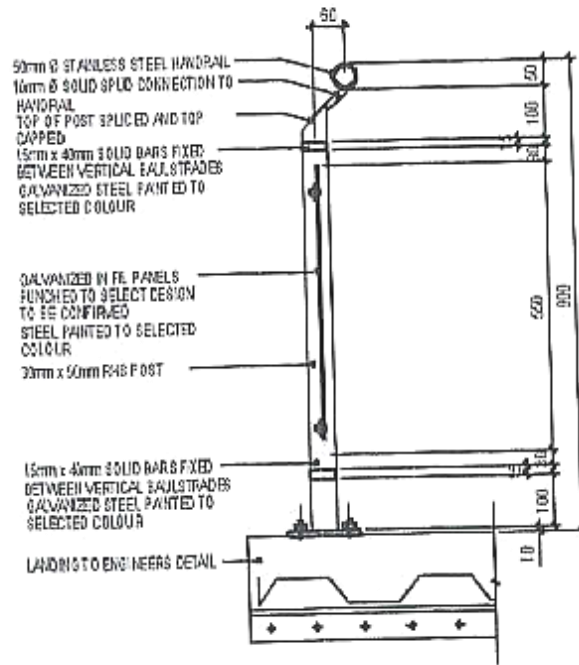

TYPICAL STAIR HANDRAIL SECTION OF BALUSTRADE

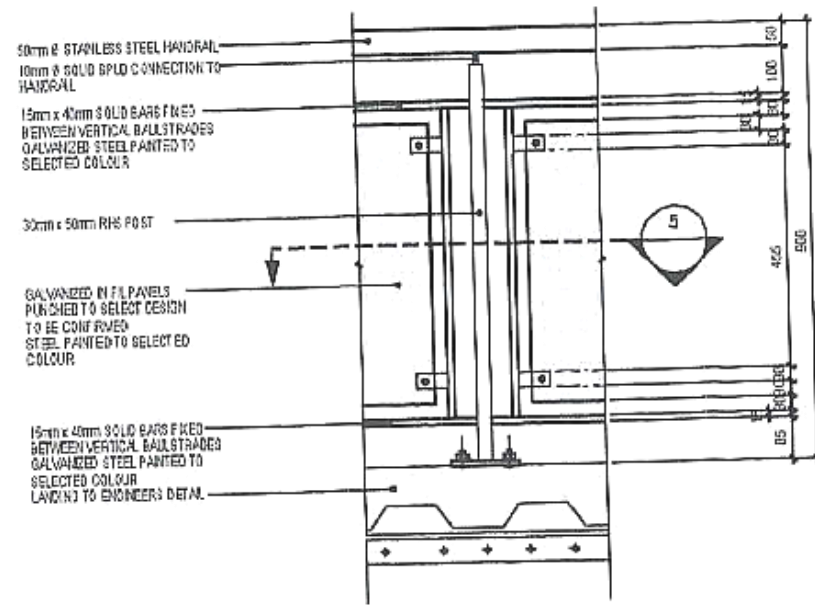

TYPICAL STAIR HANDRAIL ELEVATION OF BALUSTRADE

TYPICAL WALL BUILD UP DETAILS

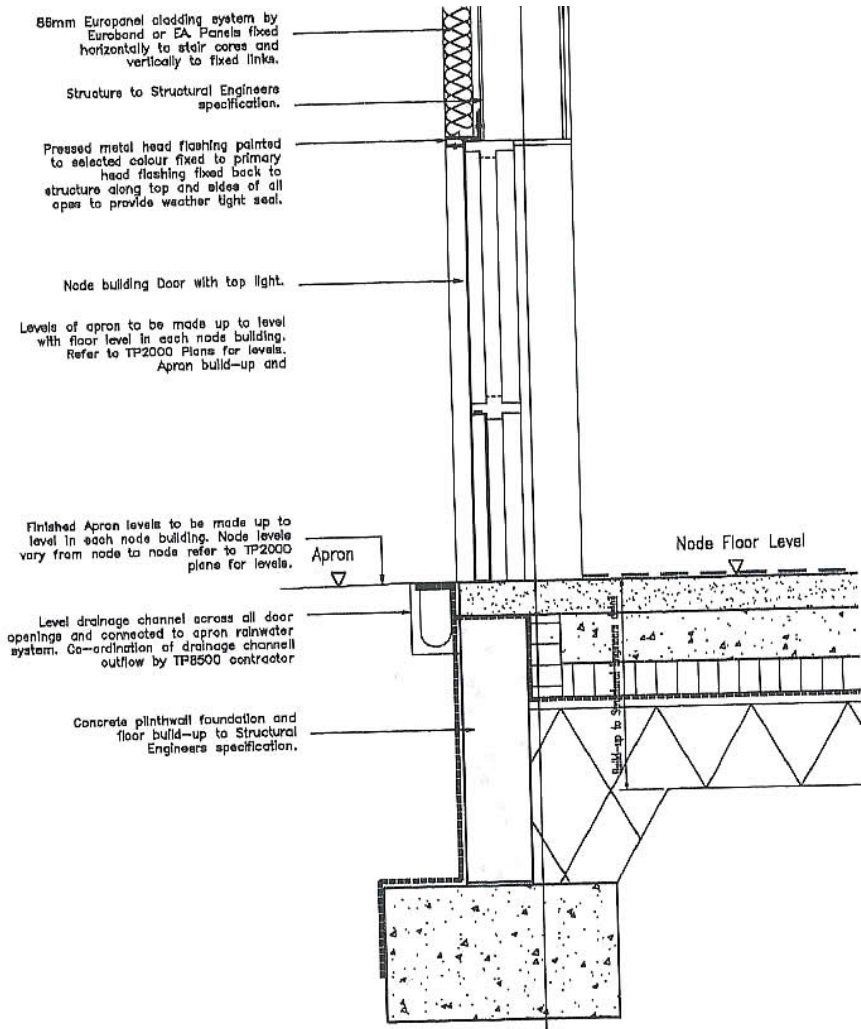

PLINTH WALL DETAIL 1

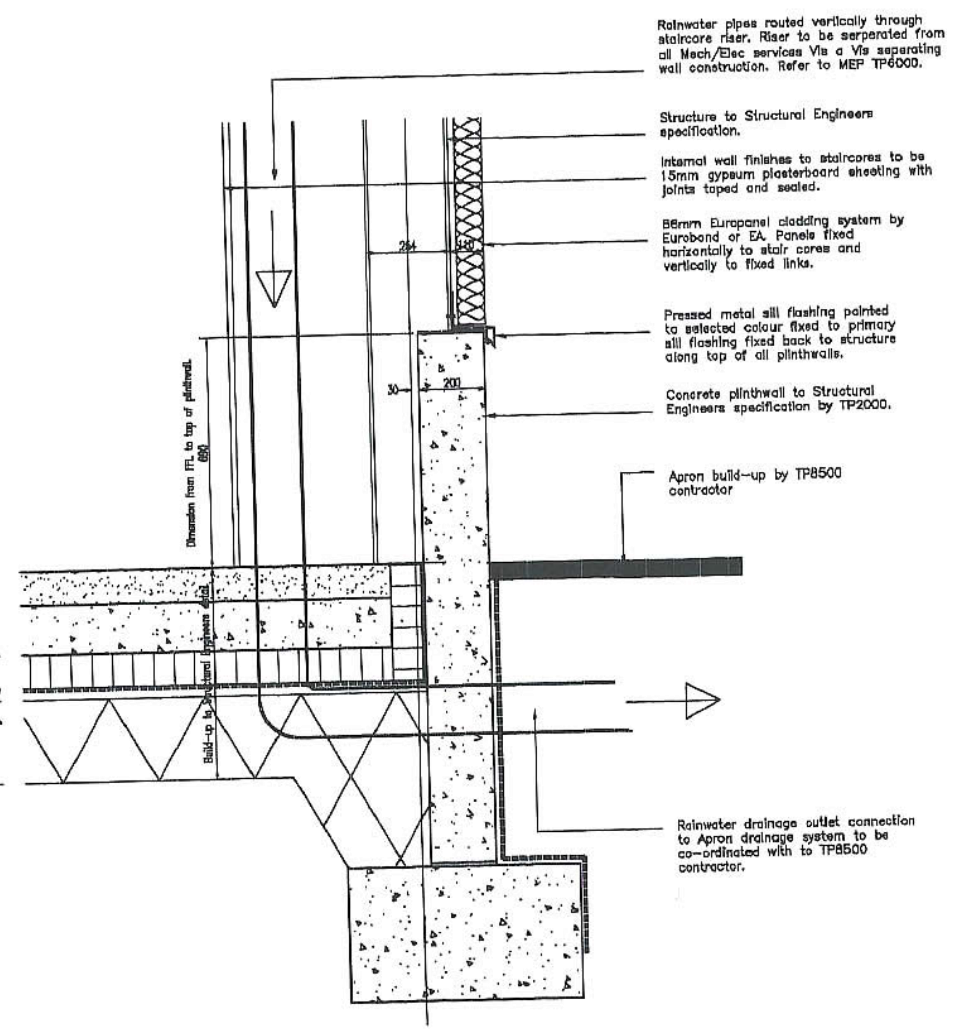

PLINTH WALL DETAIL 2

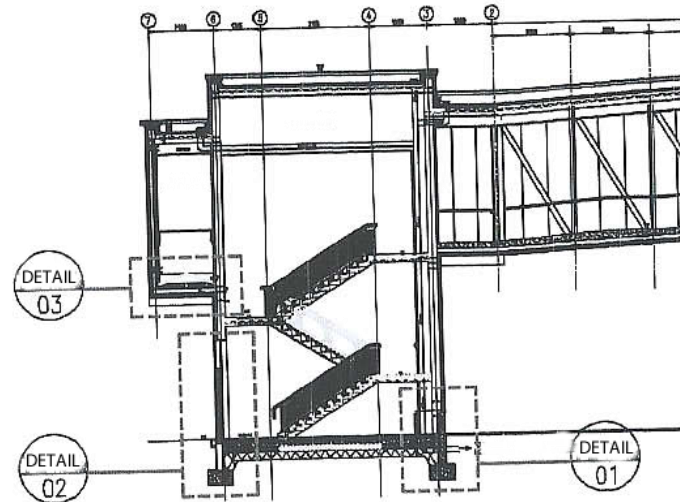

TYPICAL WALL BUILDUP DETAIL KEY

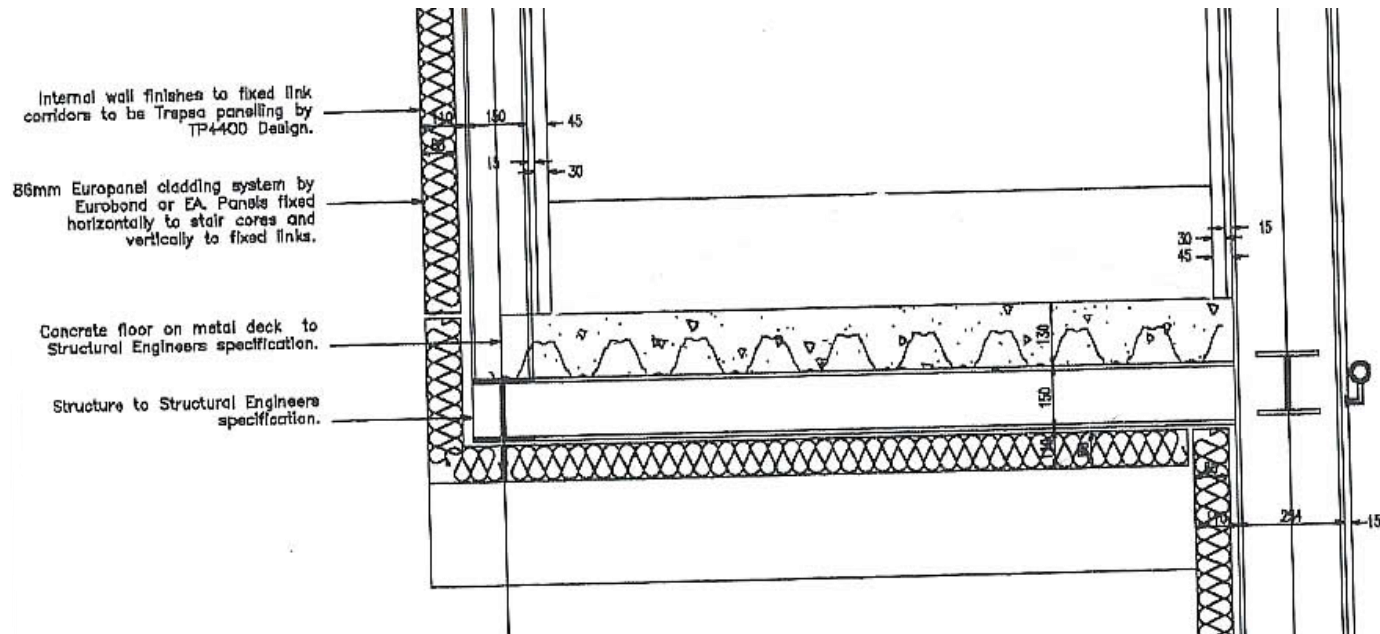

TYPICAL WALL BUILDUP DETAIL 3

TYPICAL CORRIDOR ROOF DETAILS

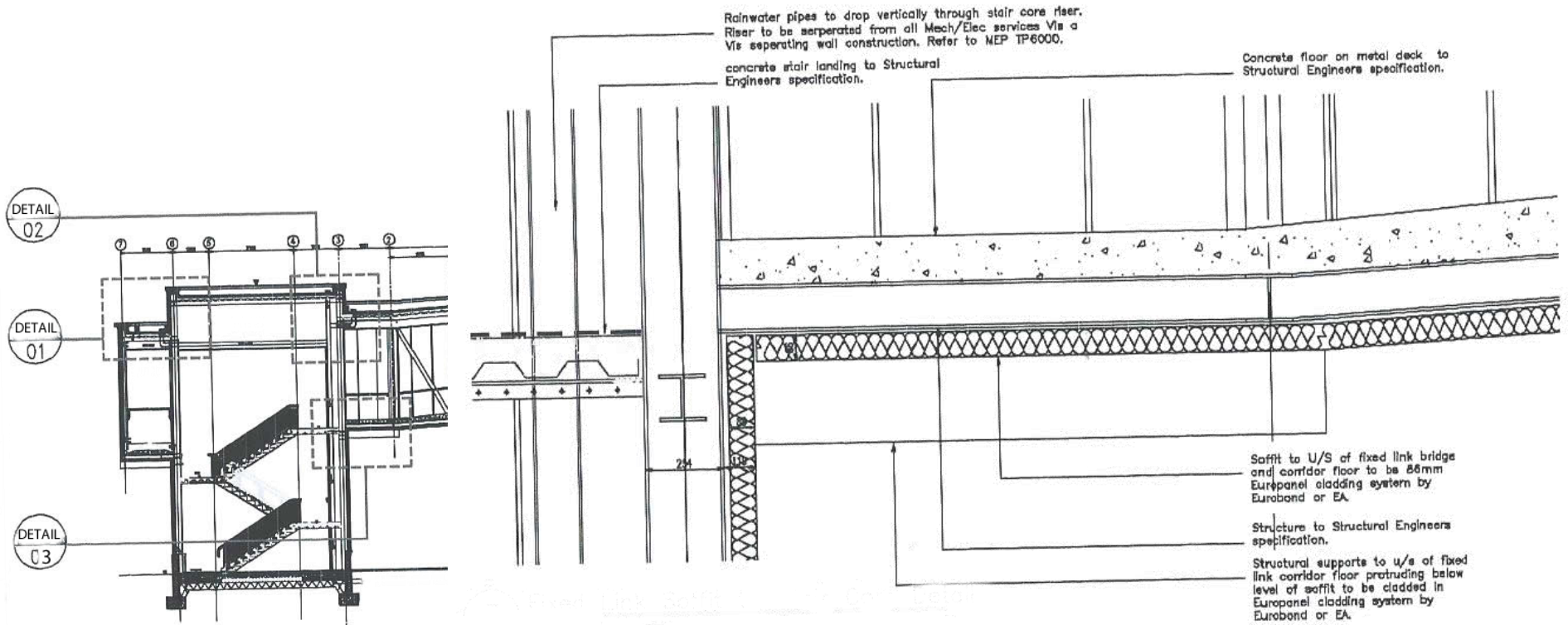

TYPICAL CORRIDOR ROOF DETAIL KEY

TYPICAL CORRIDOR ROOF DETAIL 3

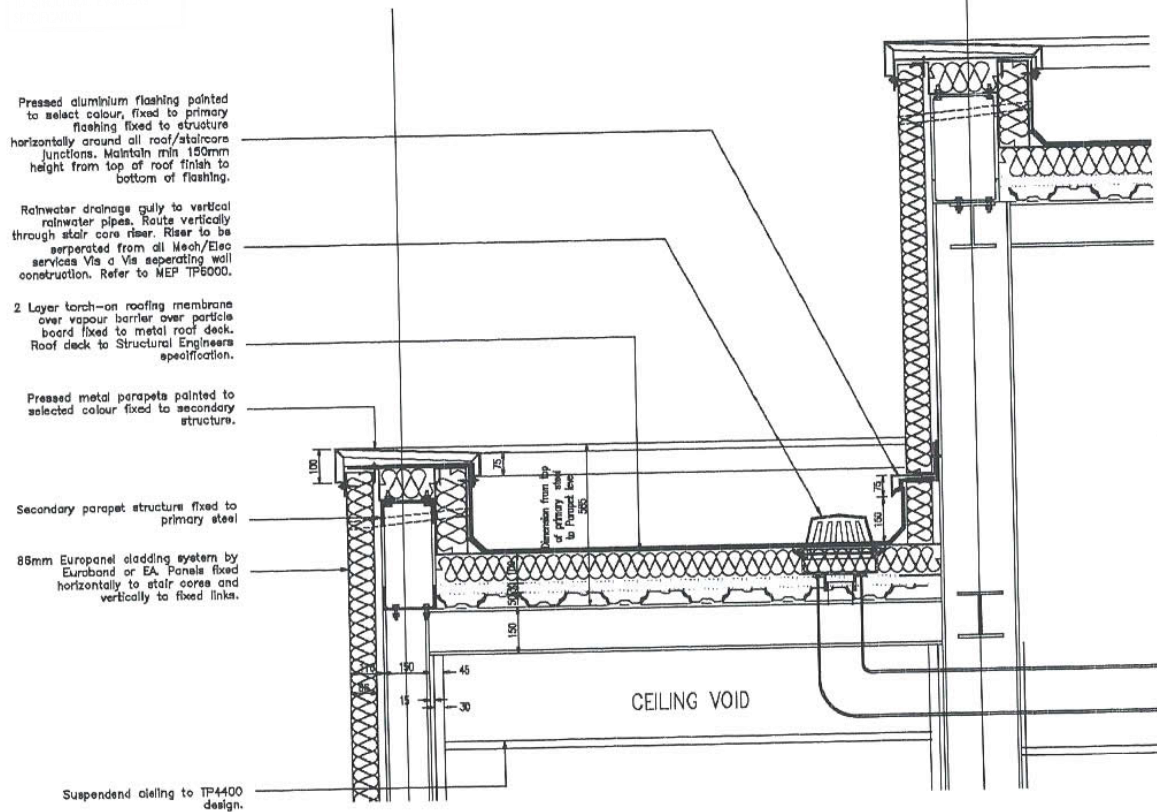

TYPICAL CORRIDOR ROOF DETAIL 1

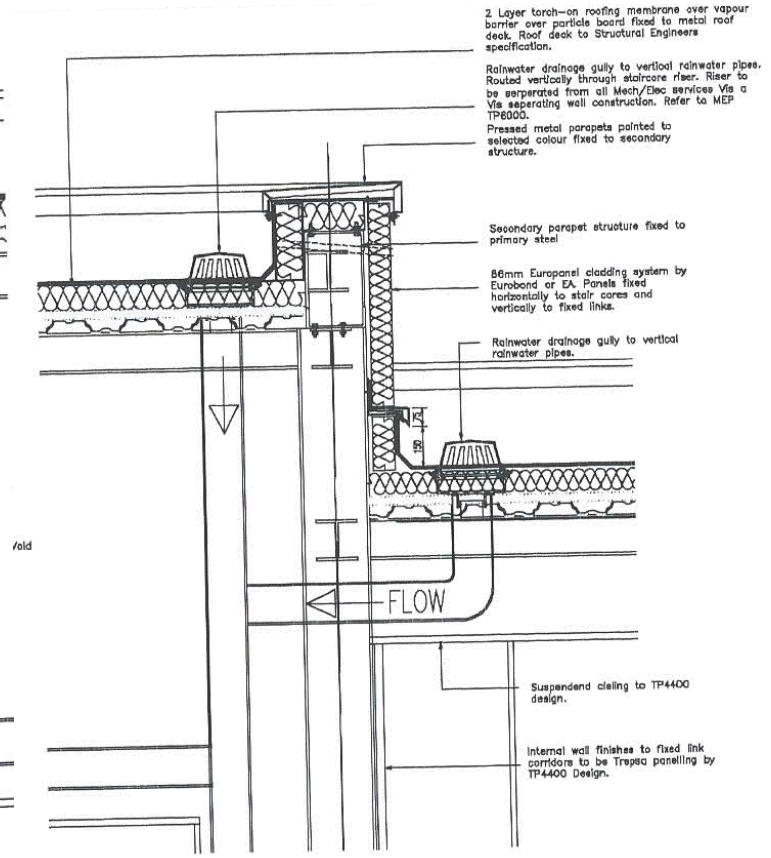

TYPICAL CORRIDOR ROOF DETAIL 2

SITE PHOTOS



PIER E FRAME SEPTEMBER 2008



PIER E FRAME DECEMBER 2008



PIER E GLAZING AND FIXED LINK AND NODE BUILDING FRAME IN PLACE FEBRUARY 2009